

Unit #4

MIS5214

Cryptography and Case Study 1

Agenda

- Cryptography terminology
- Symmetric key cryptography
 - Symmetric stream cryptography
 - Symmetric block cryptography
- Key sharing problem
- Public Key Cryptography
 - Diffie-Hellman algorithm: symmetric key generation through asynchronous cryptography
 - RSA algorithm
- Hybrid-cryptography
 - Perfect Forward Secrecy
- Case study 1

Services of cryptosystems

- **Confidentiality** – Renders information unintelligible except by authorized entities
- **Authentication** – Verifies the identity of the user or system that created, requested or provided the information
- **Nonrepudiation** – Ensure the sender cannot deny sending the information
- **Integrity** – Data has not been altered in an unauthorized manner since it was created, transmitted, or stored

Cipher = encryption algorithm

2 main attributes combined in a cypher

1. **Confusion:** usually carried out through substitution
2. **Diffusion:** Usually carried out through transposition

Example: Substitution cipher or algorithm

- A mono-alphabetic substitution cipher

ABCDEFGHIJKLMNOPQRSTUVWXYZ
ZYXWVUTSRQPONMLKJIHGFEDCBA

“SECURITY” \Leftrightarrow “HVXFIRGB”

Cipher Disk based substitution

Outer wheel is for the *plaintext* alphabet

Inner wheel is for *ciphertext*

When the outer wheel and inner wheel are both aligned at the letter "A" (i.e. position zero), there is no encryption mapping the letters on the outer wheel to letters on the inner wheel

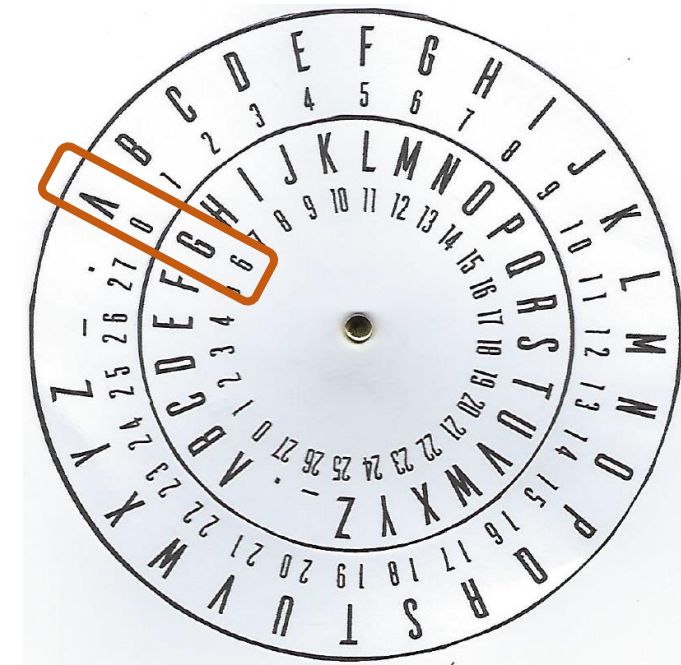
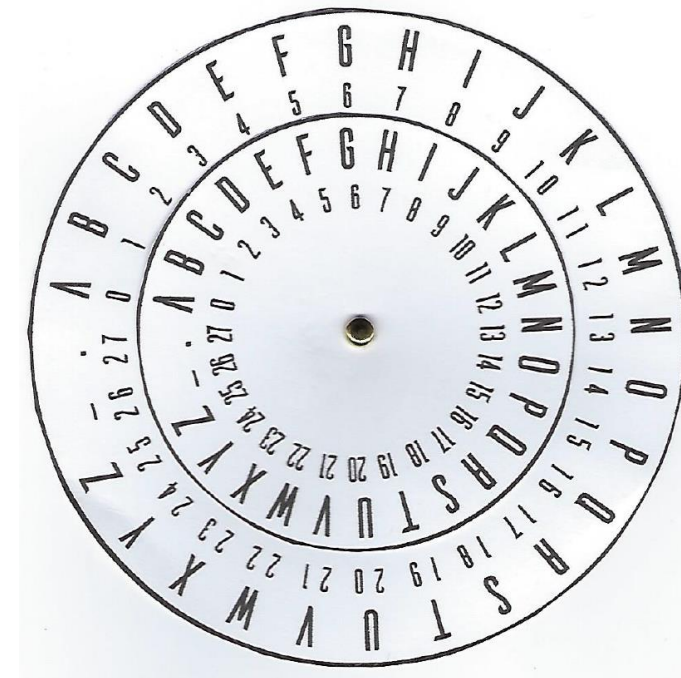

Secret

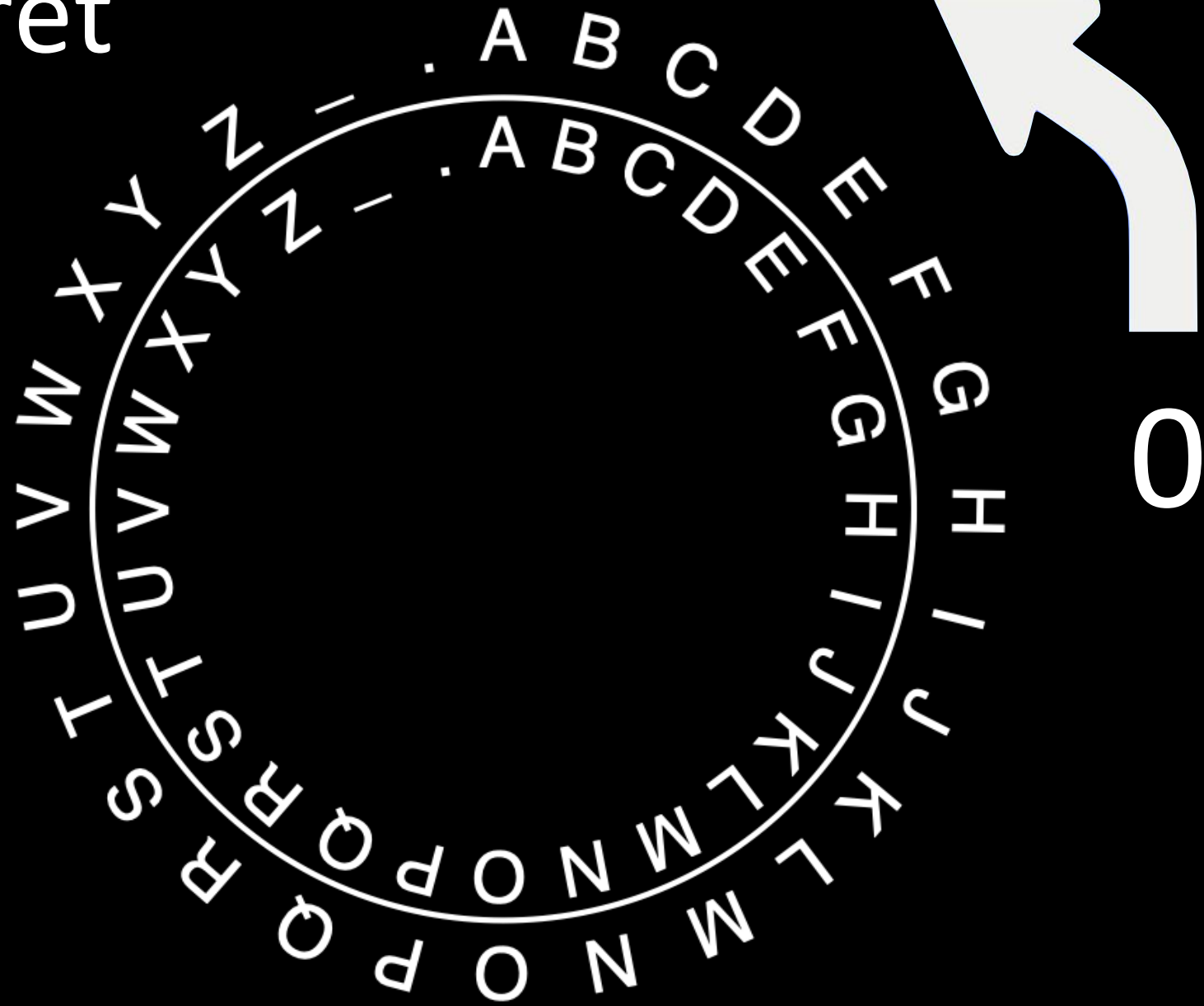

Tfdsfu

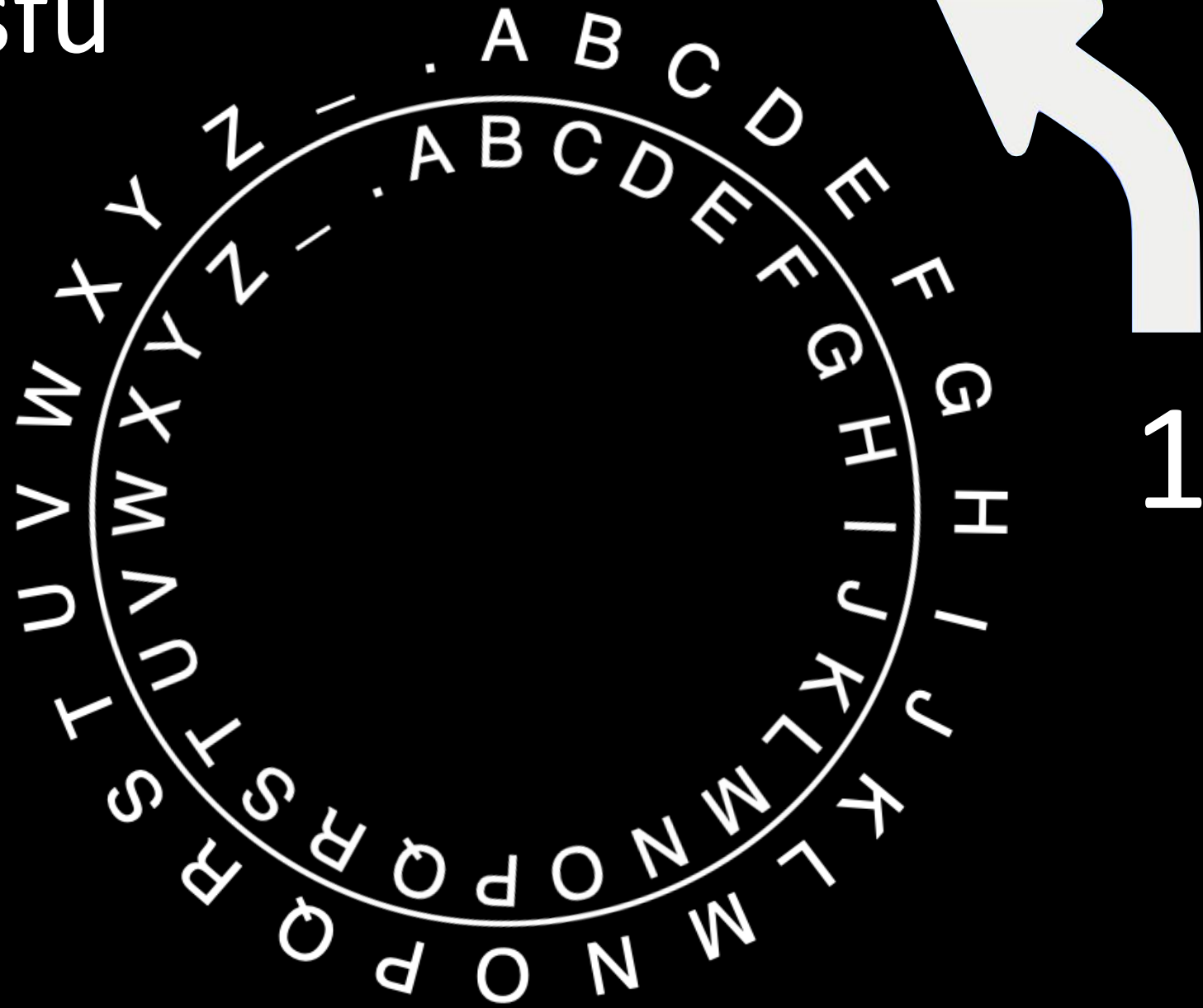

Ugetgv

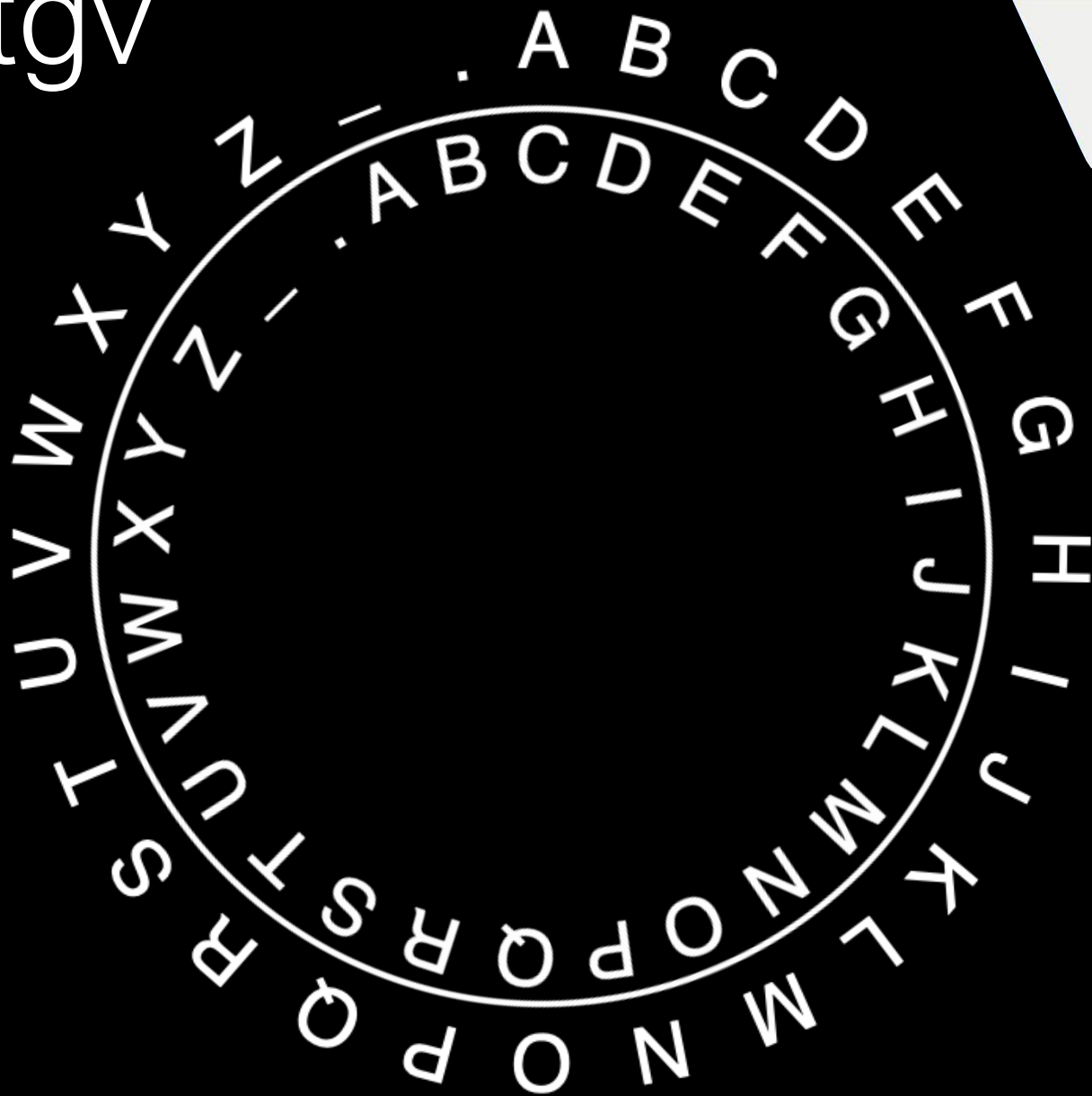

2

Keyspace is the number of possible keys

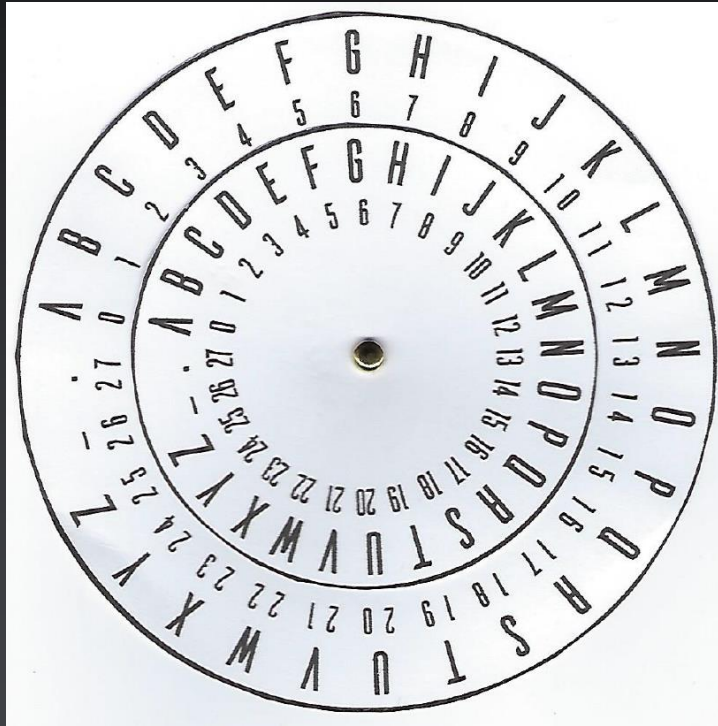

A B C D E F G H I J K L M N O P Q R S T U V W X Y Z - .

28

A B C D E F G H I J K L M N O P Q R S T U V W X Y Z - .

Question: Assuming each key is equally likely (randomly distributed) how many random guesses would be needed, on average, to find the key to decrypt the plaintext?

➤ Answer: ~ 14 , $(28 - 1) = 27$ and $27/2 = 13.5$ which is approximately 14

➤ Because the average of a uniform distribution is half

➤ Recall 26 letters in the alphabet + "." and "-" = 28, but we cannot use "0" as the key which gives us the original plaintext back the size of the alphabet

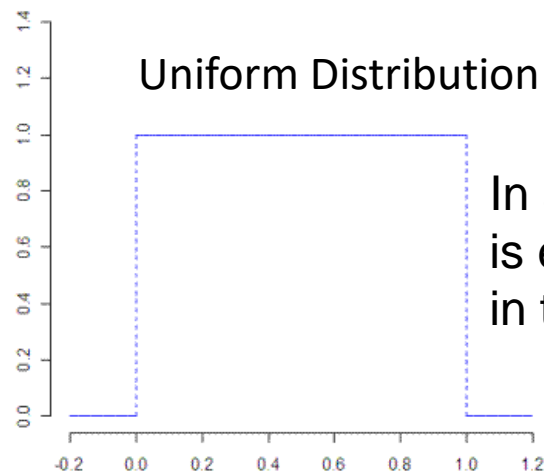
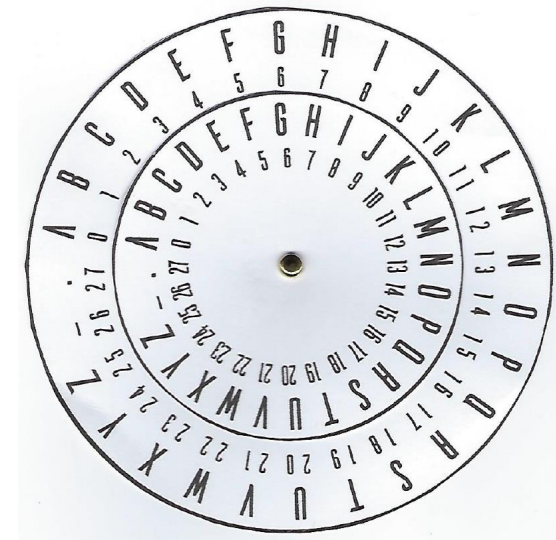

In a uniform distribution any number is equally likely, the average is right in the middle, or half the distribution

- This is important in cryptography because the average number of attempts needed to successfully guess the key through brute forcing is half of the key space
- This is true of the simple cipher wheel as well as modern encryption schemes with very large key spaces

What technique could you use to do it faster than 27 or 14 attempts?

If it was not just a lucky guess, then you were likely using “cryptanalysis”, the science of breaking codes

What strategies could you use?

Linguistic cryptanalysis examples...

- Recognizing the beginning of the word
- Looking for letter pairs
- Looking at vowels

This form of cryptanalysis uses knowledge of the English language

Linguistic cryptanalysis examples...

One form of linguistic cryptanalysis is *frequency analysis of letters used in English*

Frequency analysis recognizes that different letters have different probabilities of frequencies of use in words:

Given a sentences written in the English language

- E, T, A and O are the most common
- Z, Q and X are rare
- TH, ER, ON, and AN are the most common pairs of letters (termed bigrams or digraphs)
- SS, EE, TT, and FF are the most common repeats

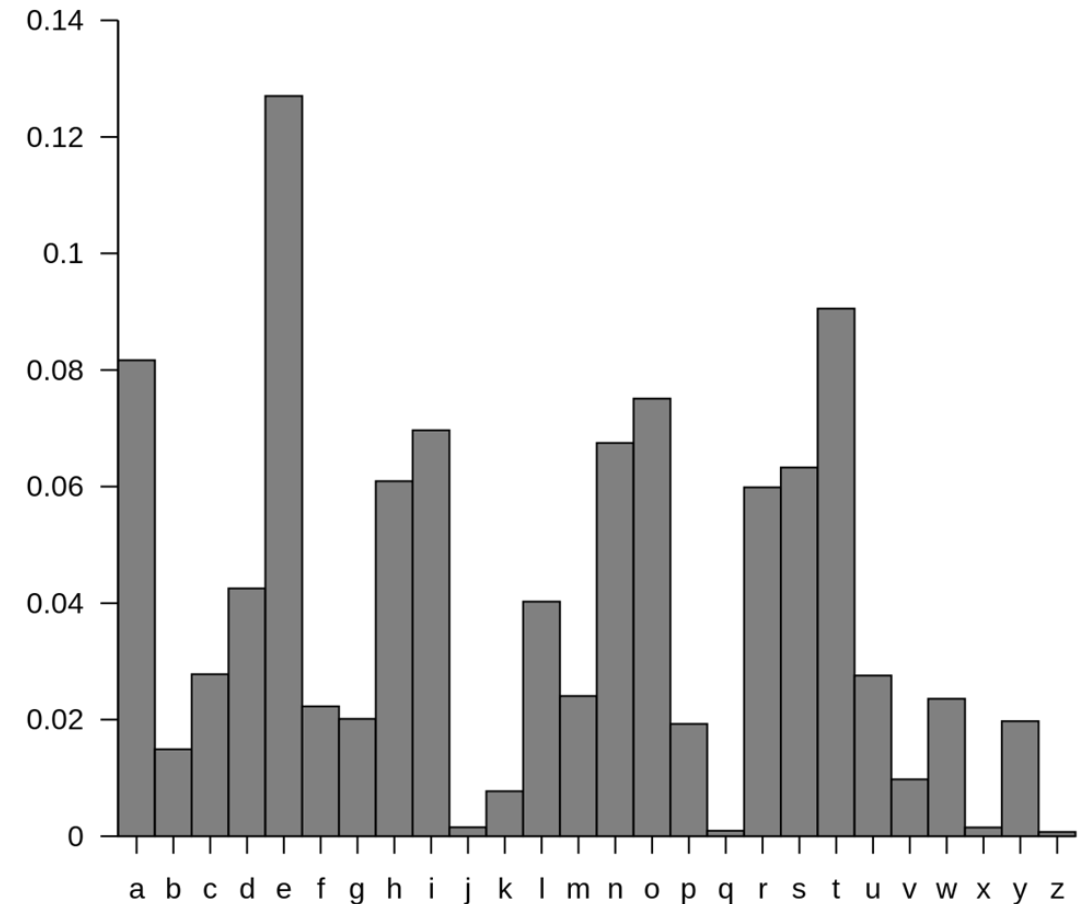

Polyalphabetic Cipher

Ciphers can be made stronger, and frequency analysis made more difficult when more than one cipher alphabet is used

- For example, encrypt the plaintext message “SEND MONEY”
 - Using the word “SECURITY” as the key, but repeat its use in the key to make it have as many letters as the plaintext:

Plaintext: SEND MONEY (10 characters including the space “_”)

Key: SECURITYSE (10 characters)

Polyalphabetic Cipher

Plaintext: SEND MONEY (10 characters including the space “_”)

Key: SECURITYSE (10 characters)

1. Encrypt by rotating the inner wheel so that “S” in the word “SECURITY” aligns with “A” on the outer wheel
Now “S” in the word “SEND” on the outer wheel maps to the letter “I” on the inner wheel, so “I” is the ciphertext
2. Next, rotate the inner wheel so that “E” in the word “SECURITY” aligns with “A” on the outer wheel. Now “E” in the word “SEND” on the outer wheel maps to “I” on the inner wheel, so “I” is the ciphertext again, even though the plaintext is different than before

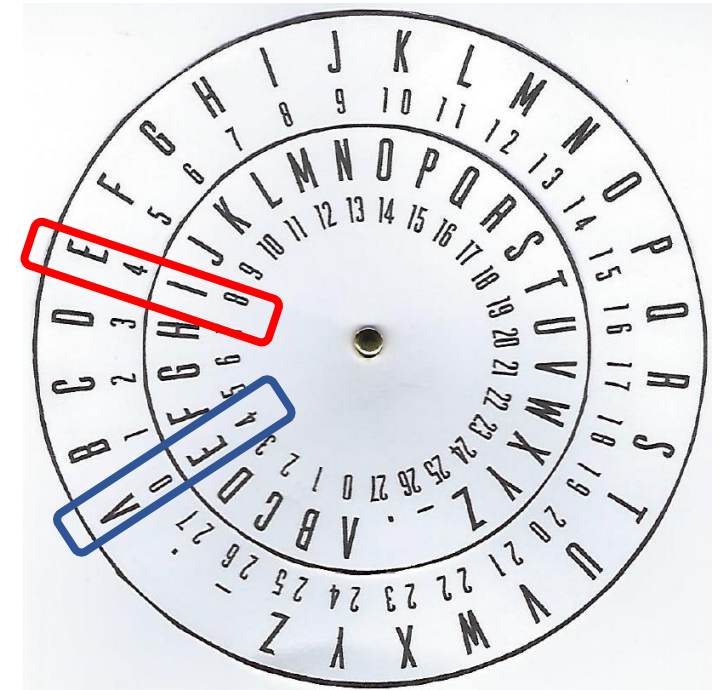
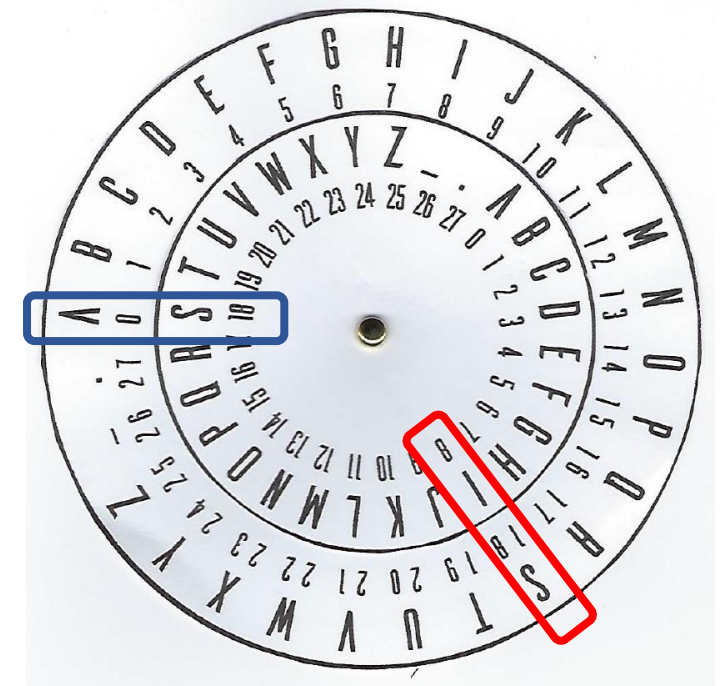

Polyalphabetic Cipher

Plaintext: SEND MONEY (10 characters including the space “_”)

Key: SECURITYSE (10 characters)

What is the rest of the ciphertext for “SEND MONEY” using the polyalphabetic key “SECURITY”?

IIPXPUFJWA

Polyalphabetic ciphers make frequency analysis more difficult

Polyalphabetic substitution is another building block of cryptography

To help you, use the following formula:

- Encryption: ciphertext = (plaintext + key) mod 28
- Decryption: plaintext = (ciphertext - key) mod 28

Number your alphabet so that it starts with zero, e.g., A = 0, Z=25, _ = 26, . = 27

This means that your alphabet will be `abcdefghijklmnopqrstuvwxyz_.`

As a general rule for shift ciphers, *the modulus is always the size of the alphabet, but you must start your alphabet at 0*

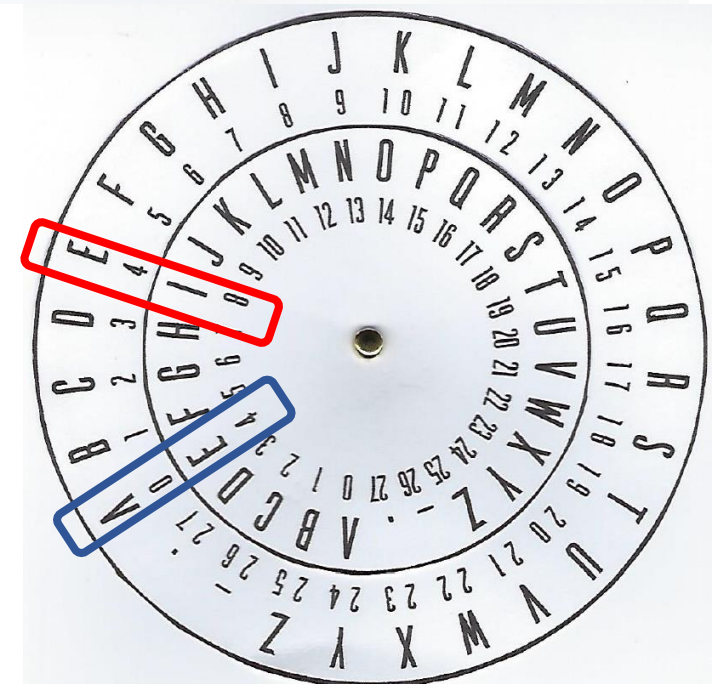
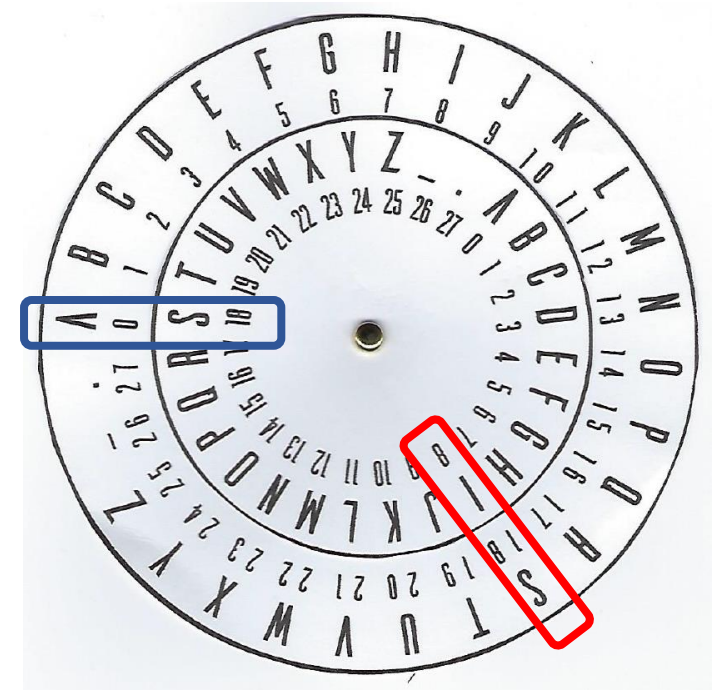

A	B	C	D	E	F	G	H	I	J	K	L	M	N	O	P	Q	R	S	T	U	V	W	X	Y	Z	_	.
0	1	2	3	4	5	6	7	8	9	10	11	12	13	14	15	16	17	18	19	20	21	22	23	24	25	26	27

Random Polyalphabetic Cipher

What if we use a random polyalphabetic key that is as long as the message?

For example, let's say our plaintext is:

We intend to begin on the first of February unrestricted submarine warfare.

And the polyalphabetic key is a string of random characters as long as the message:

ackwulsjwkblogbzckn.kqubpnnefvcebuymaclzvmzwbxpmmqwmm.tejzfutjcqrsf_hq

How could an attacker attempt to crack this message?

Is an attack possible?

Cipher = encryption algorithm

2 main attributes combined in a cypher

1. **Confusion:** usually carried out through substitution
2. **Diffusion:** Usually carried out through transposition

Binary – Decimal

0 0 0 0 0 0 0 0 = 0
1 1 1 1 1 1 1 1 = 255

2 ⁷	2 ⁶	2 ⁵	2 ⁴	2 ³	2 ²	2 ¹	2 ⁰
128	64	32	16	8	4	2	1

8 bits supports 256 numbers

Decimal - ASCII

Dec	Hex	Name	Char	Ctrl-char	Dec	Hex	Char	Dec	Hex	Char	Dec	Hex	Char
0	0	Null	NUL	CTRL-@	32	20	Space	64	40	@	96	60	`
1	1	Start of heading	SCH	CTRL-A	33	21	!	65	41	A	97	61	a
2	2	Start of text	STX	CTRL-B	34	22	"	66	42	B	98	62	b
3	3	End of text	ETX	CTRL-C	35	23	#	67	43	C	99	63	c
4	4	End of xmit	EOT	CTRL-D	36	24	\$	68	44	D	100	64	d
5	5	Enquiry	ENQ	CTRL-E	37	25	%	69	45	E	101	65	e

ASCII Character Table

Name	Hex	Dec	Name	Hex	Dec	Name	Hex	Dec	Name	Hex	Dec
. (period)	2E	046	A	41	065	L	4C	076	W	57	087
0	30	048	B	42	066	M	4D	077	X	58	088
1	31	049	C	43	067	N	4E	078	Y	59	089
2	32	050	D	44	068	O	4F	079	Z	5A	090
3	33	051	E	45	069	P	50	080			
4	34	052	F	46	070	Q	51	081			
5	35	053	G	47	071	R	52	082			
6	36	054	H	48	072	S	53	083			
7	37	055	I	49	073	T	54	084			
8	38	056	J	4A	074	U	55	085			
9	39	057	K	4B	075	V	56	086			

XOR – Exclusive OR

Creating “confusion” (i.e. substitution) through a binary mathematical function called “exclusive OR”, abbreviated as XOR

Message stream:	1001010111
Keystream:	0011101010
Ciphertext stream:	1010111101

Symmetric cryptography

Strengths:

- Much faster (less computationally intensive) than asymmetric systems.
- Hard to break if using a large key size.

Symmetric cryptography is 1,000 times faster than Asymmetric cryptography

Weaknesses:

- Requires a secure mechanism to deliver keys properly.
- Each pair of users needs a unique key, so as the number of individuals increases, so does the number of keys, possibly making key management overwhelming.
- Provides confidentiality but not authenticity or nonrepudiation.

Two types: Stream and Block Ciphers

- **Stream Ciphers** treat the message a stream of bits and performs mathematical functions on each bit individually
- **Block Ciphers** divide a message into blocks of bits and transforms the blocks one at a time

Symmetric encryption uses the same keys.

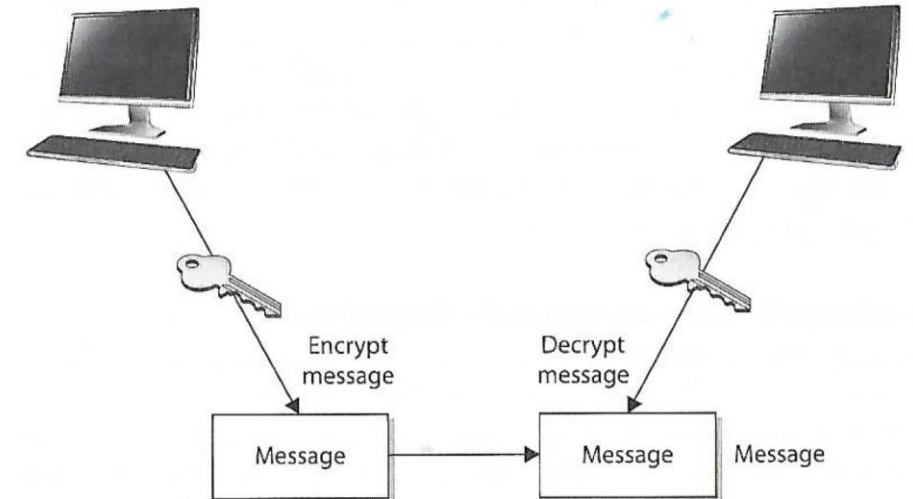

Symmetric Stream Ciphers

Pseudo-random number generator (PRNG)

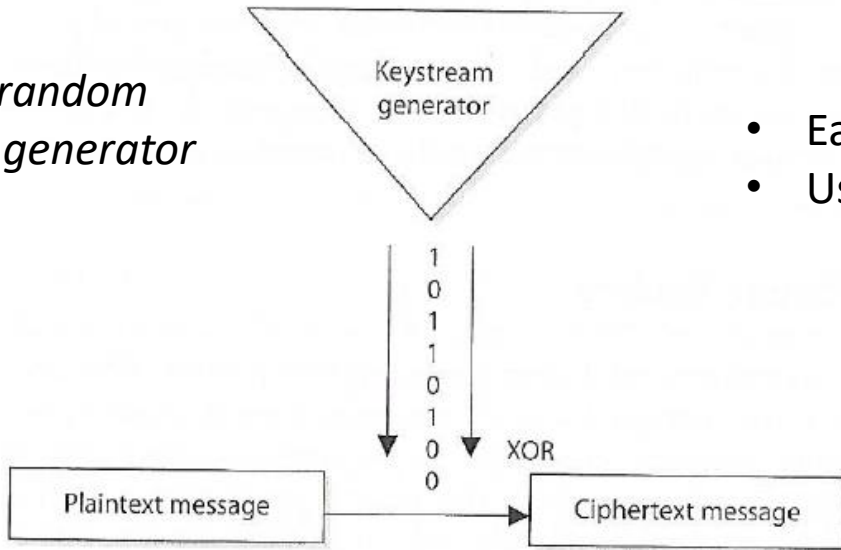

- Easy to implement in hardware
- Used in cell phones and Voice Over Internet Protocol

Wi-Fi access points (like the one on the classroom ceiling) and cell phone use stream ciphers to encrypt/decrypt data they send and receive

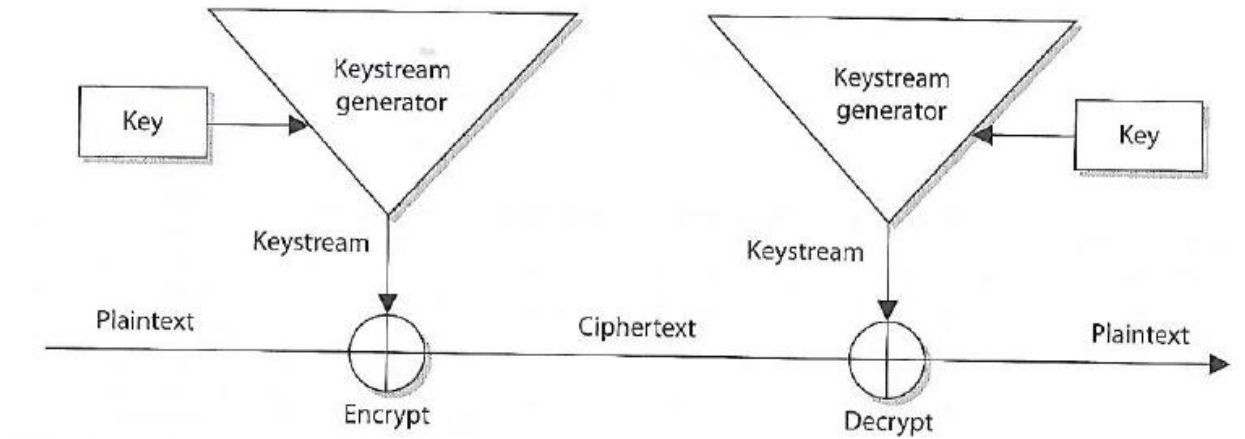

The sender and receiver must have the same key to generate the same keystream.

2 main attributes combined in a cypher

1. Confusion: usually carried out through substitution
2. **Diffusion:** Usually carried out through transposition

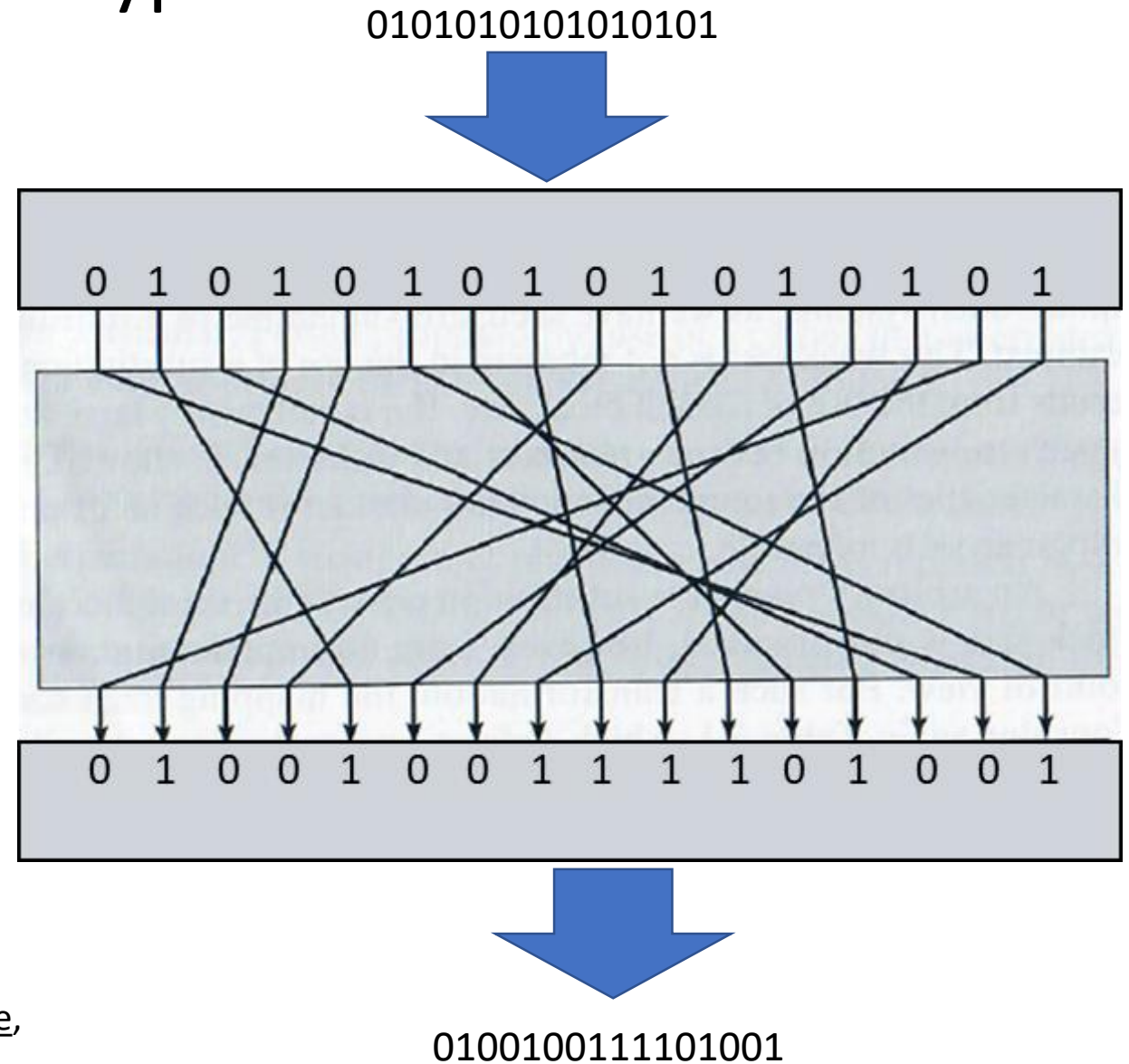

Block Ciphers versus Stream Ciphers

In contrast, block ciphers encrypt a block of bits at a time

In this example, each Substitution Box (S-box) contains a lookup table used by the algorithm as instructions on how the bits are substituted

Plaintext	Ciphertext	Ciphertext	Plaintext
0000	1110	0000	1110
0001	0100	0001	0011
0010	1101	0010	0100
0011	0001	0011	1000
0100	0010	0100	0001
0101	1111	0101	1100
0110	1011	0110	1010
0111	1000	0111	1111
1000	0011	1000	0111
1001	1010	1001	1101
1010	0110	1010	1001
1011	1100	1011	0110
1100	0101	1100	1011
1101	1001	1101	0010
1110	0000	1110	0000
1111	0111	1111	0101

Encryption table

Decryption table

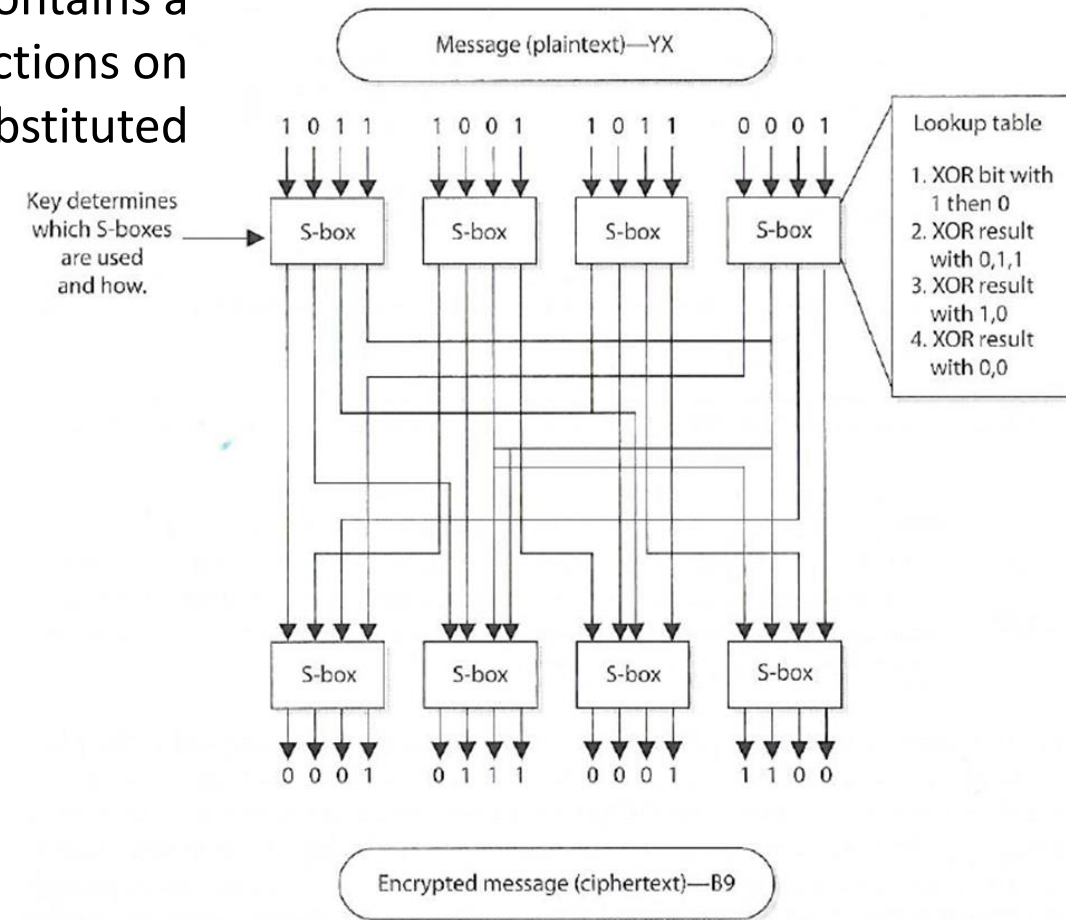

...followed by transposition...

Block Cyphers (“Cipher”)

- Message is divided into blocks of bits
- Blocks are put through encryption functions 1 block at a time

Suppose you are encrypting a 640-bit long message to send using a block cypher that uses 64 bits

- Your message would be chopped up into 10 blocks each 64 bits long
- Each block, in turn, would be run through a series of encryption functions (substitution and transposition)
- Ending up with 10 blocks of ciphertext

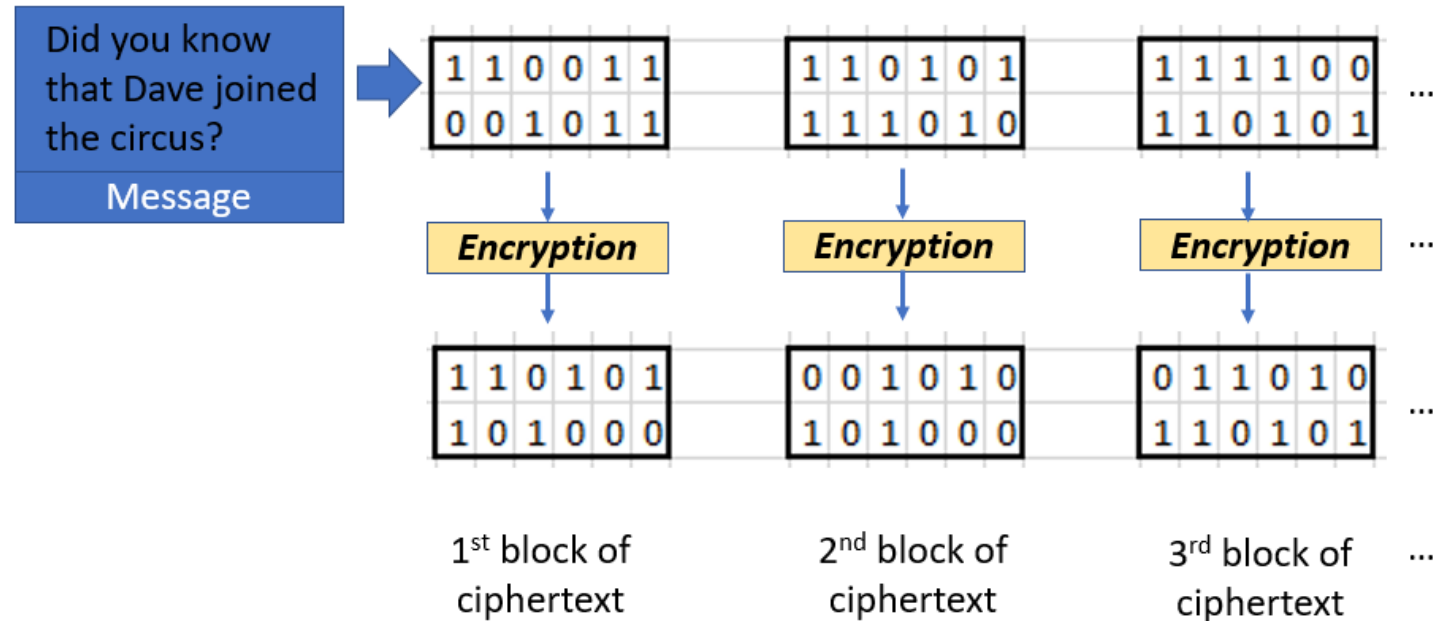

Block Ciphers

- Message is divided into blocks of bits
- Blocks are put through mathematical functions 1 block at a time

You send the message. Receiver uses the same block cipher and key (symmetric) to decipher the message

- The 10 ciphertext blocks go back through the algorithm in the reverse sequence
- Resulting in original plaintext message

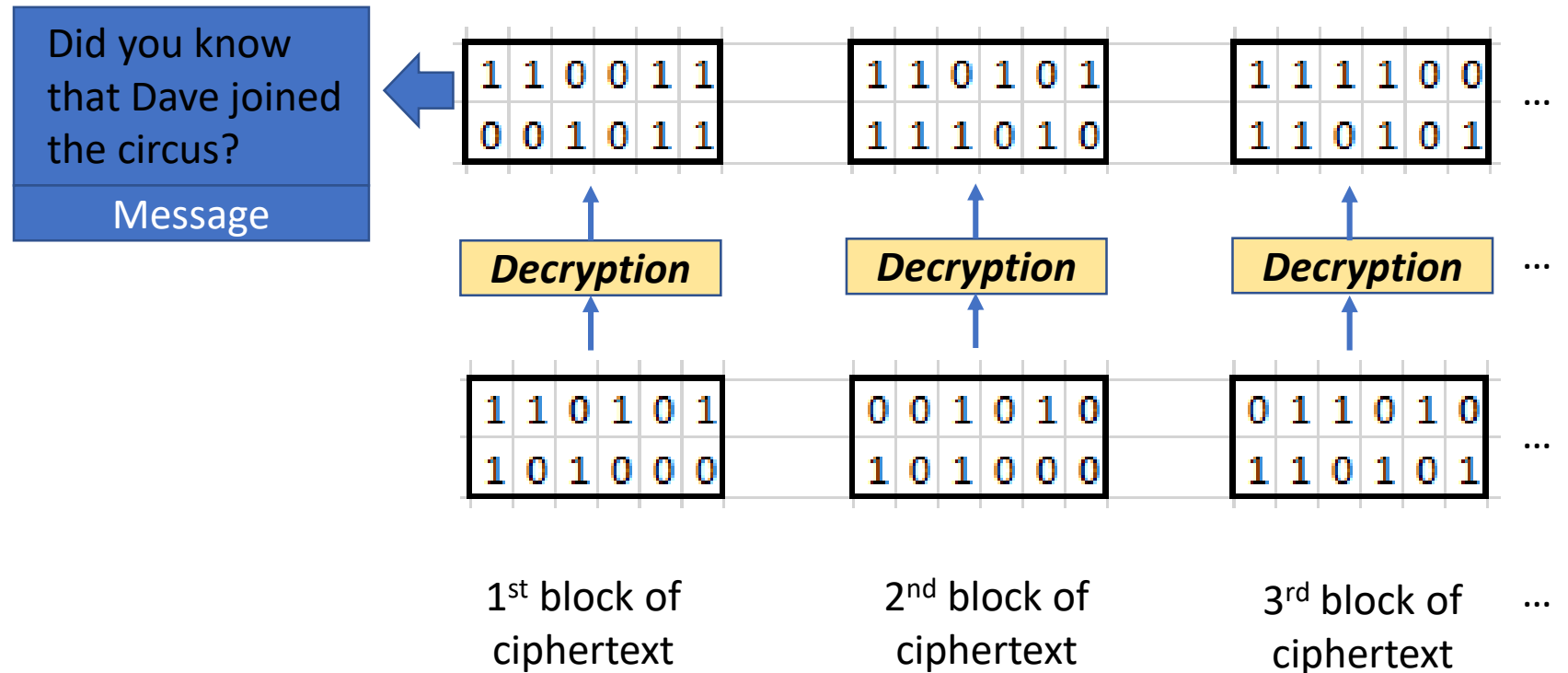

Block cipher's “mode of operation”

5 modes of operation are used to tailor them for use in different applications:

1. ECB – Electronic Code Book mode
2. CBC – Cipher Block Chaining mode
3. CFB – Cipher FeedBack mode
4. OFB – Output FeedBack mode
5. CTR – CounTeR mode

ECB – Electronic Code Book mode

- A data block of a certain size (e.g. 64 bits or 128 bits or...) is entered into the algorithm with the key, and a block of cipher text is produced

$$C_i = \text{Encrypt}(\text{Key}, P_i)$$

for $i = 1, \dots, k$

Where:

- C_i is block i of ciphertext
- P_i is a block of plaintext

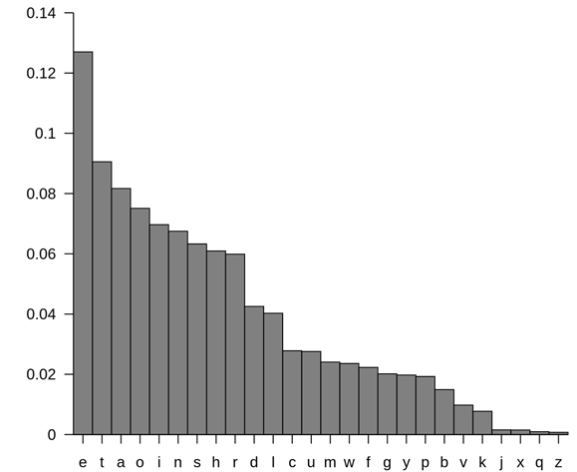

- Encrypts every block the same way every time for a given key
- Why is this a problem?
 - This is a problem because **frequency analysis** of the encrypted text can reveal a lot of information
 - Not enough randomness

CBC – Cipher Block Chaining mode

- Is much more secure
- Does not reveal a pattern of encryption for frequency analysis
- Each block of text, the key, and the value based on the previous block are processed in the algorithm and applied to the next block of text

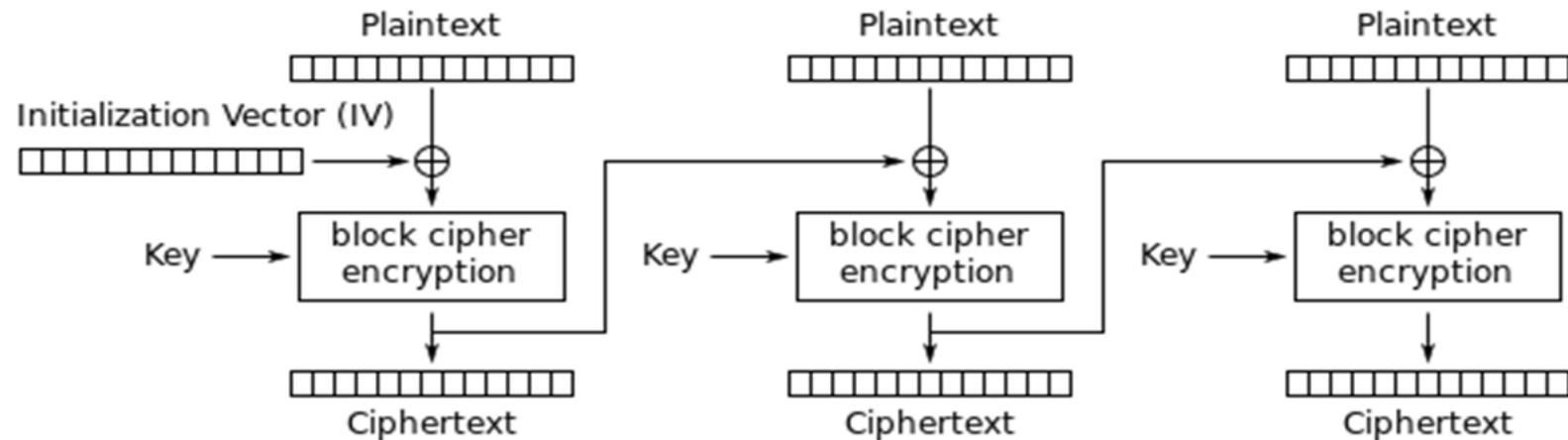

- XORs a plaintext with the **last** encrypted block before encrypting it. This ensures that the same plaintext is encrypted differently every time.
- Requires an initialization vector (or IV) to get started, since the first block doesn't have a previous encrypted block to XOR against.

CBC – Cipher Block Chaining mode

- $C_i = \text{Encrypt}(\text{Key}, P_i \oplus C_{i-1})$
for $i = 1, \dots, k$
- *Note: For $i=1$ $C_i = IV$ (initialization vector is used)*

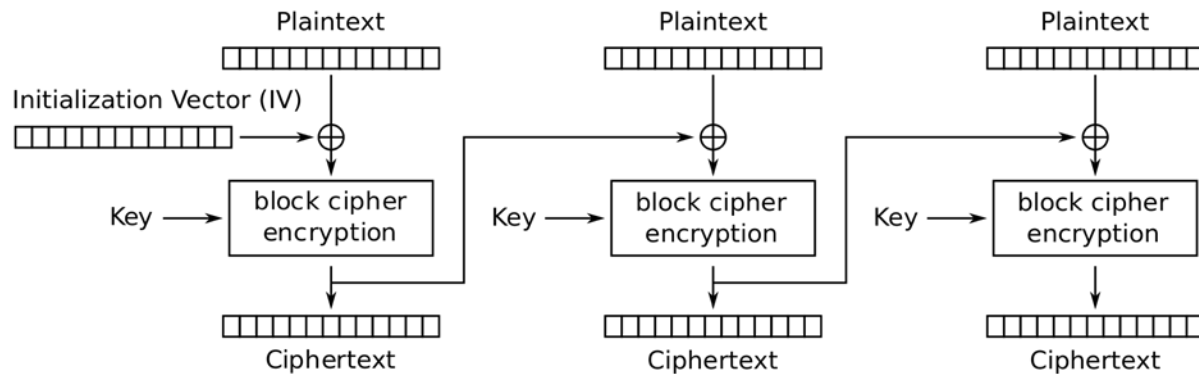

Cipher Block Chaining (CBC) mode encryption

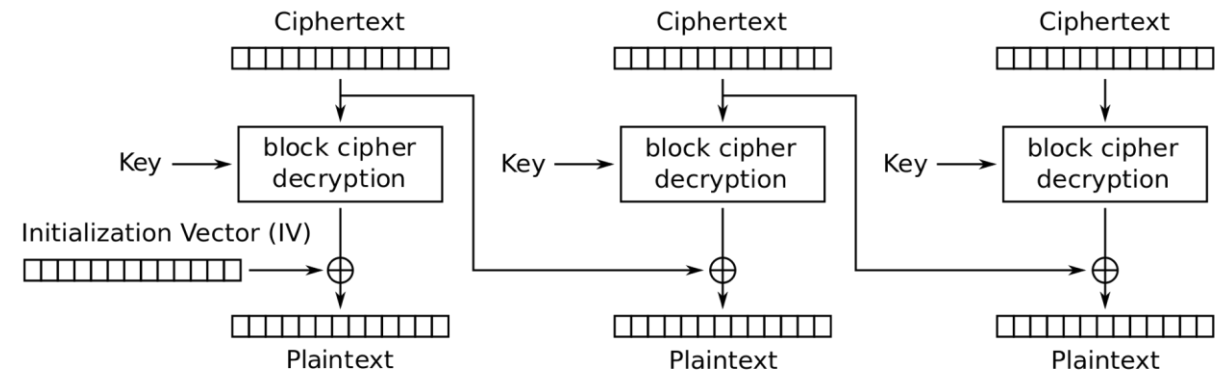

Cipher Block Chaining (CBC) mode decryption



Original Image



Block cipher with ECB
(Electronic Code Book)
encryption

Not good!

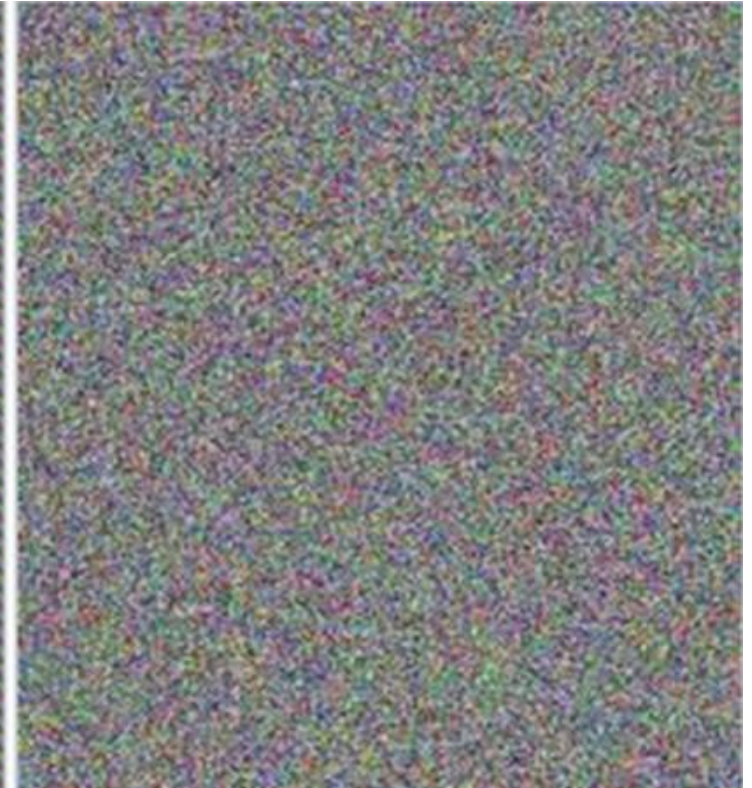

Block cipher with CBC
(Cipher Block Chaining) or any
of the other modes of
encryption

These are good!

Cryptanalysis Attacks

- Brute force
 - Trying all key values in the keyspace
- Frequency Analysis
 - Guess values based on frequency of occurrence
- Dictionary Attack
 - Find plaintext based on common words
- Known Plaintext
 - Format or content of plaintext available
- Chosen Plaintext
 - Attack can encrypt chosen plaintext
- Chosen Ciphertext
 - Decrypt known ciphertext to discover key
- Random Number Generator (RNG) Attack
 - Predict initialization vector used by an algorithm
- Social Engineering
 - Humans are the weakest link

Modern Block Ciphers

- Use block sizes of 128-bits or greater
 - Examples of Block Ciphers that can be used are:
 - AES
 - Blowfish
 - Twofish
 - Serpent
- Do not use these examples of block ciphers which use 64-bit blocks, which are too small to be secure include:
 - DES
 - 3DES

Agenda

- ✓ Cryptography terminology
- ✓ Symmetric key cryptography
 - ✓ Symmetric stream cryptography
 - ✓ Symmetric block cryptography
- Key sharing problem
- Public Key Cryptography
 - Diffie-Hellman algorithm: symmetric key generation through asynchronous cryptography
 - RSA algorithm
- Hybrid-cryptography
 - Perfect Forward Secrecy
- Case study 1

Key sharing problem

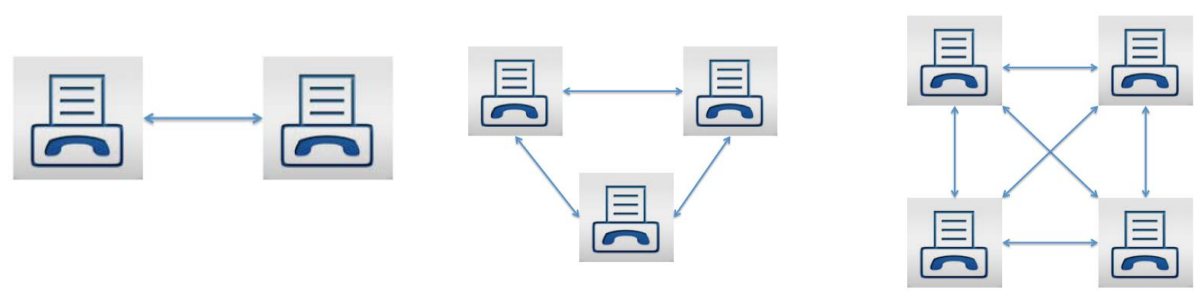

Sharing cryptographic keys has been a problem throughout history

- The number of pairs of keys (“secure network connections”) grows at a near exponential rate (i.e. geometric rate) as the number of users increases

Users	Symmetric Keys
1	0
2	1
3	3
4	6
5	10
6	15
7	21
8	28
9	36
10	45
11	55
12	66
13	78
14	91
15	105
...	...

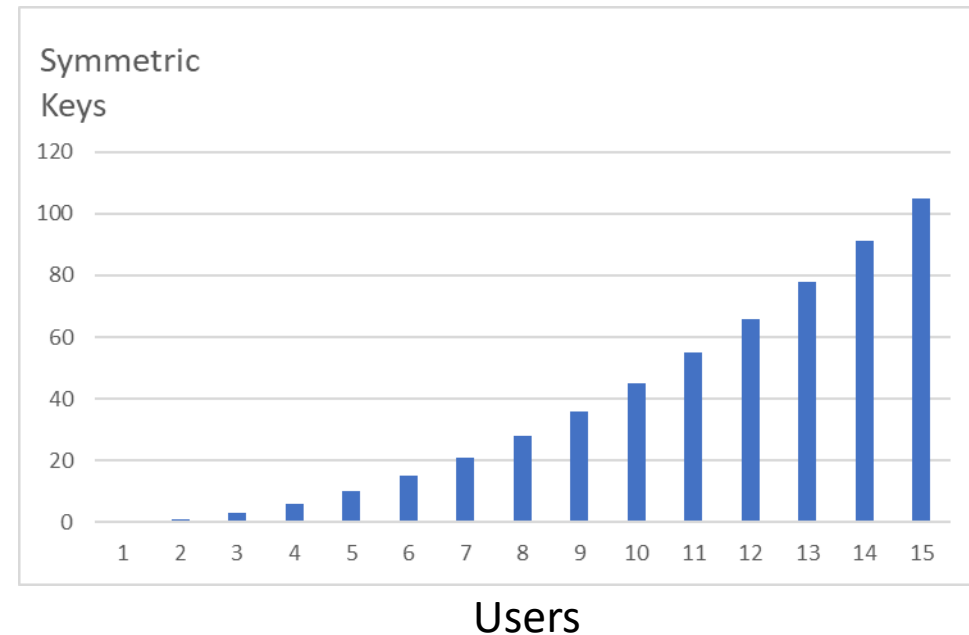

Key sharing problem

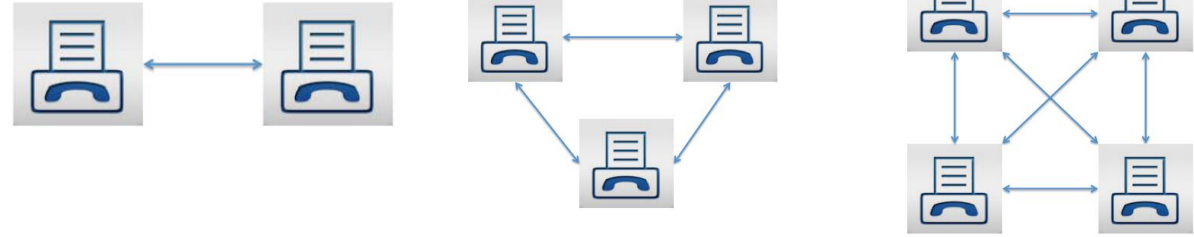

- The number of pairs of keys needed for “n” users is determined by an equation known as [Metcalf’s Law](#)
- Number of key pairs needed for n users = $(n*(n-1))/2$
 - *The reason for the n-1 is that you do not need to communicate with yourself*
- For MIS 4596 with 22 students how many keys would we need:

$$(22 * 21)/2 = 231 \text{ keys}$$



Diffie-Hellman Algorithm: *Secret symmetric key derivation through public key sharing*

Assumptions:

A prime number is a positive whole number whose only factors (i.e. integer divisors) are 1 and the number itself (e.g. 2, 3, 5, 7, 11, 13, 17, 19, 23, ...). Bob & Alice want to compute a shared secret key to protect confidentiality of their conversation. Eve eavesdrops...

Algorithm:

1. Bob & Alice publicly agree on “**p**” called *prime modulus* (e.g. **p = 23**) & “**g**” called *generator* (e.g. **g = 5**), Eve overhears
2. Bob & Alice each choose their own secret key:
 - Bob’s secret key is referred to as “**x_bob**” which is a number between 1 and p-1 (e.g. **x_bob = 12**)
 - Alice’s secret key is referred to as “**x_alice**” which also is a number between 1 and p-1 (e.g. **x_alice = 7**)
3. Bob & Alice each computes their own public key, which they share with each other and Eve intercepts...
 - Bob computes: **y_bob = g^{x_bob} mod p** which is: **y_bob = 5¹² mod 23 = 18** which he shares with Alice (and Eve)
 - Alice computes: **y_alice = g^{x_alice} mod p** which is: **y_alice = 5⁷ mod 23 = 17** which she shares with Bob (and Eve)
4. Bob & Alice each compute their shared secret symmetric key
 - Bob computes: **y_alice^{x_bob} mod p** which is: **17¹² mod 23 = 6**
 - Alice computes: **y_bob^{x_alice} mod p** which is: **18⁷ mod 23 = 6**
5. Bob & Alice now have a **shared secret (“symmetric”) key = 6**
6. Eve has Bob & Alice’s public keys: y_bob=18 & y_alice=17, prime modulus: p=23 and generator: g=5, but not their secret keys x_bob = 12 & x_alice = 7
 - *Eve cannot calculate Bob& Alice’s shared symmetric secret key from their public keys, p and g alone – even though she knows they are using the Diffie-Hellman algorithm!*

Exercise You and 2 neighbors become: Bob, Alice, and Eve

Run the algorithm together

1. Bob & Alice publicly agree on “**p**” called *prime modulus* (e.g. **p = 31**) and “**g**” called *generator* (e.g. **g = 3**), Eve overhears
2. Bob & Alice each choose your own secret key:
 - Bob’s secret key is referred to as “**x_bob**” which is a number between 1 and p-1 (write it down but keep it secret)
 - Alice’s secret key is referred to as “**x_alice**” which also is a number between 1 and p-1 (write it down but keep it secret)
3. Bob & Alice each computes your own public key, which you share with each other, and Eve intercepts...
 - Bob computes: $y_{\text{bob}} = g^{x_{\text{bob}}} \bmod p$ which he writes down and shares with Alice (and Eve)
 - Alice computes: $y_{\text{alice}} = g^{x_{\text{alice}}} \bmod p$ which she writes down and shares with Bob (and Eve)
4. Bob & Alice each secretly compute your shared secret symmetric key which you write down and do not share
 - Bob computes: $y_{\text{alice}}^{x_{\text{bob}}} \bmod p$ which he writes down and does not share
 - Alice computes: $y_{\text{bob}}^{x_{\text{alice}}} \bmod p$ which she writes down and does not share
5. Bob & Alice now have a **shared secret (“symmetric”) key** compare your secret keys and confirm they are the same
6. Eve has Bob & Alice’s public keys: **y_bob** & **y_alice**, prime modulus: **p** and generator: **g**, but not their secret keys **x_bob** & **x_alice**
 - *Eve cannot calculate Bob& Alice’s shared symmetric secret key from their public keys, p and g alone – even though she knows they are using the Diffie-Hellman algorithm!*

In practice, p must be much larger prime number... this is a 4096-bit p

857,756,147,438,808,767,721,482,523,862,479,196,091,217,066,271,200,126,894,701,702,329,327,8
72,802,487,425,224,246,373,206,756,773,954,180,315,945,664,685,564,049,690,107,228,861,210,05
3,005,306,168,041,237,244,792,245,832,497,260,206,801,417,396,745,674,574,281,768,112,711,519,
809,332,223,737,878,554,093,201,446,763,995,425,025,965,323,912,149,043,161,823,975,594,943,9
15,411,109,637,902,372,642,611,214,196,649,667,036,726,005,577,041,694,781,738,635,943,018,156
,362,403,714,091,905,448,620,990,965,500,814,912,289,738,636,687,051,381,358,564,729,963,735,7
82,176,280,511,819,070,673,927,579,180,484,836,950,910,945,840,410,470,935,832,100,360,510,117
,962,261,152,920,101,946,255,789,679,435,711,472,267,368,823,730,863,971,596,718,223,674,224,1
06,003,985,209,174,353,308,077,140,794,884,546,003,360,030,727,697,326,025,663,819,442,780,10
5,880,604,943,197,516,223,343,068,846,392,924,237,875,653,640,416,933,764,628,191,065,601,980,
281,442,005,263,033,849,543,723,716,743,986,123,624,356,871,152,793,177,027,462,801,070,011,5
26,783,269,474,338,816,734,553,122,757,257,382,121,230,562,181,721,318,331,271,107,036,972,78
8,062,816,322,387,506,944,045,038,739,178,684,349,474,317,534,892,731,313,651,324,179,101,369,
222,316,429,969,662,605,450,068,078,088,031,941,042,867,503,697,721,512,539,949,128,099,005,1
60,179,345,242,776,041,458,121,259,813,719,561,319,392,760,414,249,584,984,440,063,314,771,03
9,261,920,249,005,444,014,069,555,961,131,639,966,539,872,980,057,279,636,609,441,274,119,014,
567,294,590,620,498,019,375,631,405,622,479,332,810,401,520,856,695,524,524,855,468,645,479,0
42,909,834,183,316,487,318,824,544,358,235,183,243,643

Diffie-Hellman

- Uses asymmetric public and private keys to exchange a symmetric key
- Does not use asymmetric keys for confidentiality (i.e. to encrypt or decrypt any messages)
- Users/systems need to negotiate a new key for every new person
- No authentication, no non-repudiation

Diffie-Hellman was vulnerable to man-in-the-middle attack, because no authentication occurs before public keys are exchanged

1. Tanya sends her public key to Erika, but Lance grabs the key during transmission so it never makes it to Erika
2. Lance spoofs Tanya's identity and sends over his public key to Erika. Erika now thinks she has Tanya's public key
3. Erika sends her public key to Tanya, but Lance grabs the key during transmission so it never makes it to Tanya
4. Lance spoofs Erika's identity and sends over his public key to Tanya. Tanya now thinks she has Erika's public key
5. Tanya combines her private key and Lance's public key and creates a symmetric key S1
6. Lance combines his private key and Tanya's public key and creates symmetric key S1
7. Erika combines her private key and Lance's public key and creates symmetric key S2
8. Lance combines his private key and Erika's public key and creates symmetric key S2
9. Now Tanya and Lance share a symmetric key (S1) and Erika and Lance share a different symmetric key (S2). Tanya and Erika think they are sharing a key between themselves and do not realize Lance is involved
10. Tanya writes a message to Erika, and uses her symmetric key (S1) to encrypt the message, and sends it
11. Lance grabs the message and decrypts it with symmetric key S1, reads or modifies the message and re-encrypts it with symmetric key S2, and then sends it to Erika
12. Erika takes symmetric key S2 and uses it to decrypt and read the message....

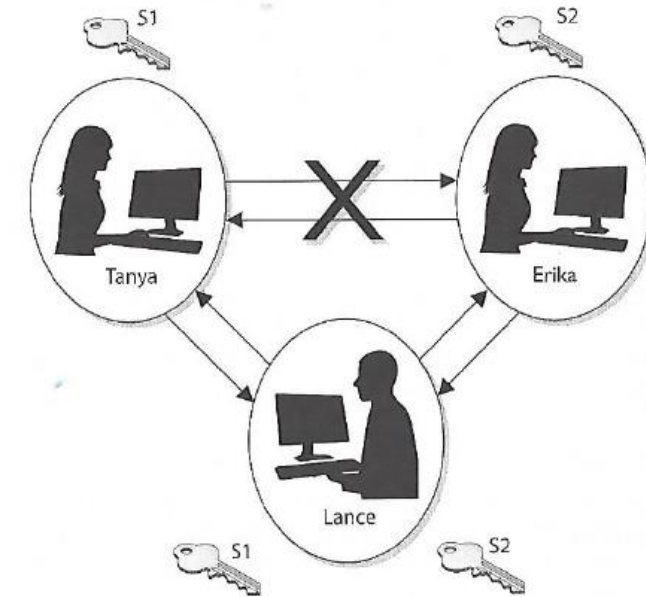

Agenda

- ✓ Cryptography terminology
- ✓ Symmetric key cryptography
 - ✓ Symmetric stream cryptography
 - ✓ Symmetric block cryptography
- ✓ Key sharing problem
- Public Key Cryptography
 - Diffie-Hellman algorithm: symmetric key generation through asynchronous cryptography
 - RSA algorithm
- Hybrid-cryptography
 - Perfect Forward Secrecy
- Case study 1

Symmetric versus asymmetric algorithms

- Symmetric cryptography
 - Use a copied pair of symmetric (identical) secret keys
 - The sender and the receiver use the same key for encryption and decryption functions
 - Confidentiality, but no integrity, authentication nor non-repudiation
- Asymmetric cryptography
 - Also known as “public key cryptography”
 - Use different (“asymmetric”) keys for encryption and decryption
 - One is called the “private key” and the other is the “public key”
 - Confidentiality, but also want authenticity and non-repudiation

Asymmetric cryptography

- **Public and Private** keys are mathematically related
 - Public keys are generated from private key
 - Private keys cannot be derived from the associated public key (if it falls into the wrong hands)
- **Public key** can be known by everyone
- **Private key** must be known and used only by the owner

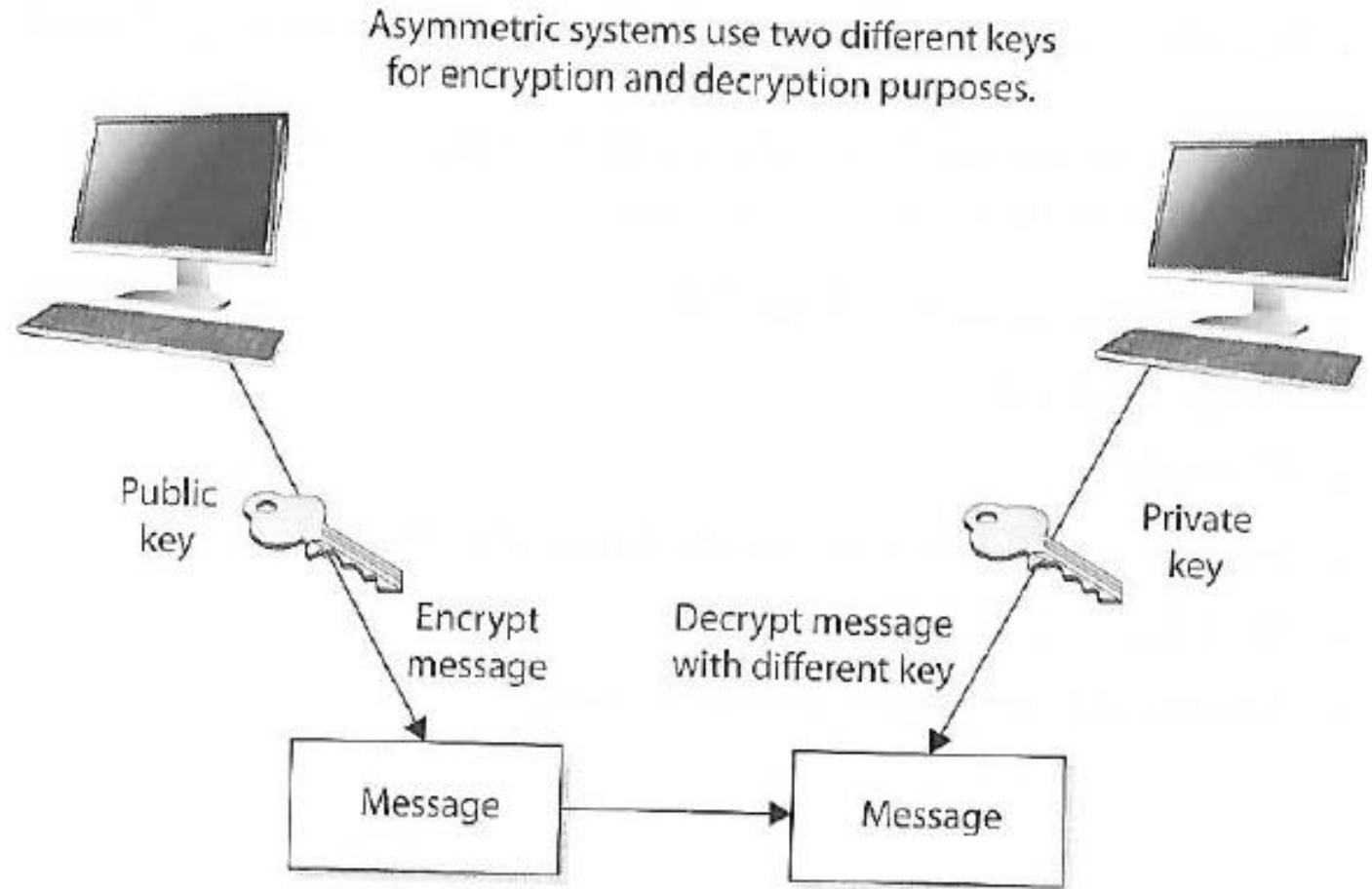

Asymmetric cryptography is computationally intensive and much slower (1,000 times slower) than symmetric cryptography

Quick review

1. If a symmetric key is encrypted with a receiver's public key, what security service is provided?
 - **Confidentiality**: only the receiver's private key can be used to decrypt the symmetric key, and only the receiver should have access to this private key

Quick review

2. If data is encrypted with the sender's private key, what security services are provided?
 - **Authenticity** of the sender and nonrepudiation. If the receiver can decrypt the encrypted data with the sender's public key, then receiver knows the data was encrypted with the sender's private key

Quick review

3. Why do we encrypt the message with the symmetric key rather than the asymmetric key?
 - **Because the asymmetric key algorithm is too slow**



Leonard **A**dleman

Adi **S**hamir

Ron **R**ivest

RSA

RSA Public Key Algorithm

- Most popular worldwide standard, that can be used for:
 - Asymmetric encryption/decryption
 - Key exchange (i.e. used to encrypt AES symmetric key)
 - Digital signatures
- In one direction, RSA provides:
 - Confidentiality through encryption
 - Authentication and non-repudiation through signature verification
- In the inverse direction, RSA provides:
 - Confidentiality through decryption
 - Authentication and non-repudiation through signature generation

RSA Public Key Algorithm

- Based on factoring large numbers into their prime numbers
 - A prime number is a positive whole number whose only factors (i.e. integer divisors) are 1 and the number itself
 - E.g. 2, 3, 5, 7, 11, 13, 17, 19, 23, ...
 - Prime number factoring is
 - Easy when you know the result and one of the factors
 - $6,700,283 = 1889 * 3547$
 - Difficult when you do not know the factors, and the result is large
 - $6,700,283 = \text{prime1} * \text{prime2}$

912,000,833,142,392,234,931,095,438,312,170,357,695,712,756,726,097,734,441,072,301,836,8
39,393,353,139,295,831,007,333,431,845,325,988,055,078,535,723,070,121,899,982,515,821,09
6,513,935,693,429,159,810,068,629,730,360,987,721,191,239,128,388,101,705,884,309,757,897,
995,146,963,367,920,258,875,045,283,800,013,428,503,089,286,243,910,365,443,336,583,304,5
89,741,301,149,906,707,508,832,951,802,034,609,255,816,376,427,847,745,175,505,389,216,57
5,446,117,214,435,309,308,014,792,888,796,704,735,885,959,753,047,089,134,349,280,135,328,
216,026,587,690,550,563,014,619,967,646,165,581,934,916,994,388,164,807,475,497,618,817,1
78,492,168,759,798,526,076,195,659,132,696,724,374,189,538,701,725,588,364,053,265,311,71
3,122,599,620,063,110,587,984,125,160,066,509,094,636,495,654,197,043,440,384,099,590,663,
387,607,347,763,569,889,588,046,648,769,380,051,353,352,323,215,616,700,132,767,221,738,2
55,618,066,992,935,073,985,886,089,858,691,117,257,124,338,259,178,666,315,503,726,679,90
4,506,880,795,225,928,179,249,708,512,521,519,802,379,088,471,059,576,692,488,554,724,378,
606,462,675,913,887,571,281,558,908,666,408,509,112,360,978,089,673,490,666,194,566,892,4
24,767,464,525,985,354,883,620,245,066,389,972,670,528,760,628,056,151,340,458,770,638,78
3,170,937,336,003,358,144,954,416,252,316,459,167,693,365,704,770,051,596,394,325,584,518,
899,185,083,613,743,340,976,318,518,122,032,762,826,960,167,883,646,888,151,502,959,194,1
55,684,395,680,807,784,172,903,618,731,005,977,092,813,955,195,470,328,083,428,604,222,13
8,565,171,106,482,154,997,950,843,259,717,191,116,046,110,961,976,117,683,744,708,282,531,
877,426,978,230,302,213,288,137,147

prime₁ * prime₂ =

912,000,833,142,392,234,931,095,438,312,
39,393,353,139,295,831,007,333,431,845,3
6,513,935,693,429,159,810,068,629,730,36
995,146,963,367,920,258,875,045,283,800,
89,741,301,149,906,707,508,832,951,802,0
5,446,117,214,435,309,308,014,792,888,79
216,026,587,690,550,563,014,619,967,646,
78,492,168,759,798,526,076,195,659,132,6
3,122,599,620,063,110,587,984,125,160,06
387,607,347,763,569,889,588,046,648,769,
55,618,066,992,935,073,985,886,089,858,6
4,506,880,795,225,928,179,249,708,512,52
606,462,675,913,887,571,281,558,908,666,
24,767,464,525,985,354,883,620,245,066,3
3,170,937,336,003,358,144,954,416,252,31
899,185,083,613,743,340,976,318,518,122,
55,684,395,680,807,784,172,903,618,731,0
8,565,171,106,482,154,997,950,843,259,71
877,426,978,230,302,213,288,137,147

Public Key algorithms

- Fundamental security elements in cryptosystems, applications and protocols
- Assure confidentiality, authenticity and non-repudiation of electronic communications and data storage
- Provide:
 - Key distribution and secrecy (e.g. Diffie–Hellman key exchange)
 - Digital signatures (e.g. Digital Signature Algorithm)
 - Both: key distribution and secrecy and digital signatures (e.g., RSA, ECC)

Elliptic-curve cryptography (ECC)

- Alternate approach to public-key cryptography based on algebraic structure of elliptic curves (based on Galois fields)
- Provides much the same security functionality as Diffie-Hellman and RSA:
 - Encryption/decryption (confidentiality)
 - Secure key distribution (authenticity, confidentiality)
 - Digital signatures (authenticity, non-repudiation)

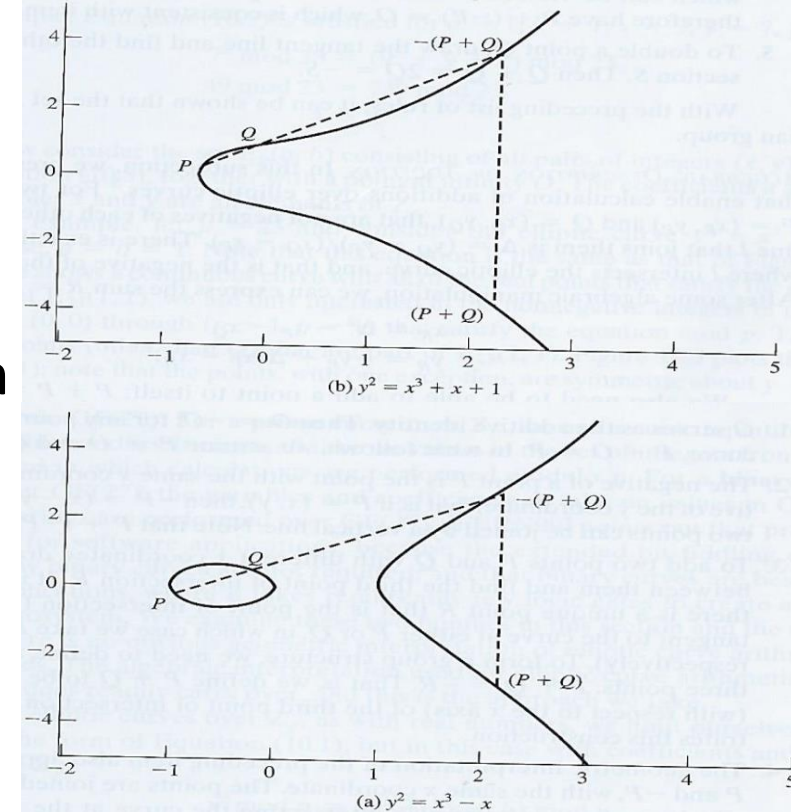

Examples of an elliptic curves

- ECC's is much more efficient than RSA and the other asymmetric algorithms
 - Requires less bits and smaller keys than RSA for achieving the same level of security in its calculations and other algorithms
 - ECC's efficiency makes it very good for wireless devices and cellular phones with limited processing capacity, storage, power supply and bandwidth

Elliptic-curve cryptography (ECC)

Elliptic-curve Diffie–Hellman (ECDH) is a variant of the Diffie–Hellman protocol using elliptic-curve cryptography

- A key agreement protocol that allows two parties, each having an elliptic-curve public–private key pair, to establish a shared secret over an insecure channel
- The shared secret may be directly used as a key, or to derive another key
- The key, or the derived key, can then be used to encrypt subsequent communications using a symmetric-key cipher

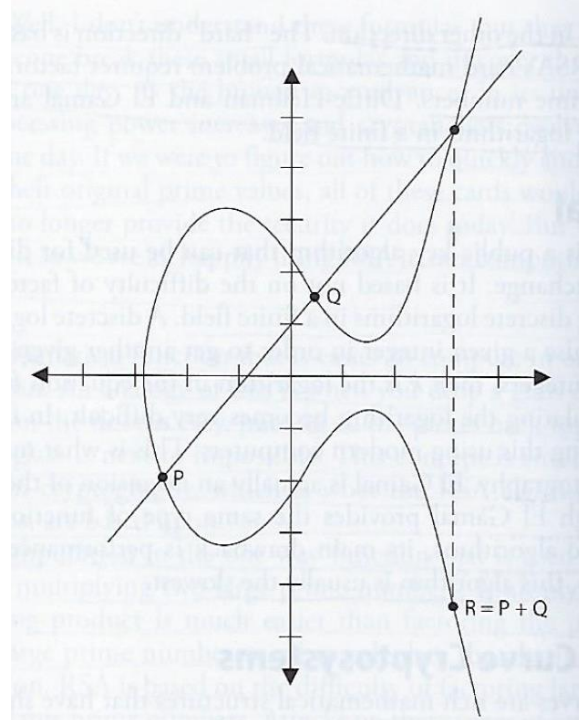

Example of an elliptic curve

Public Key Management

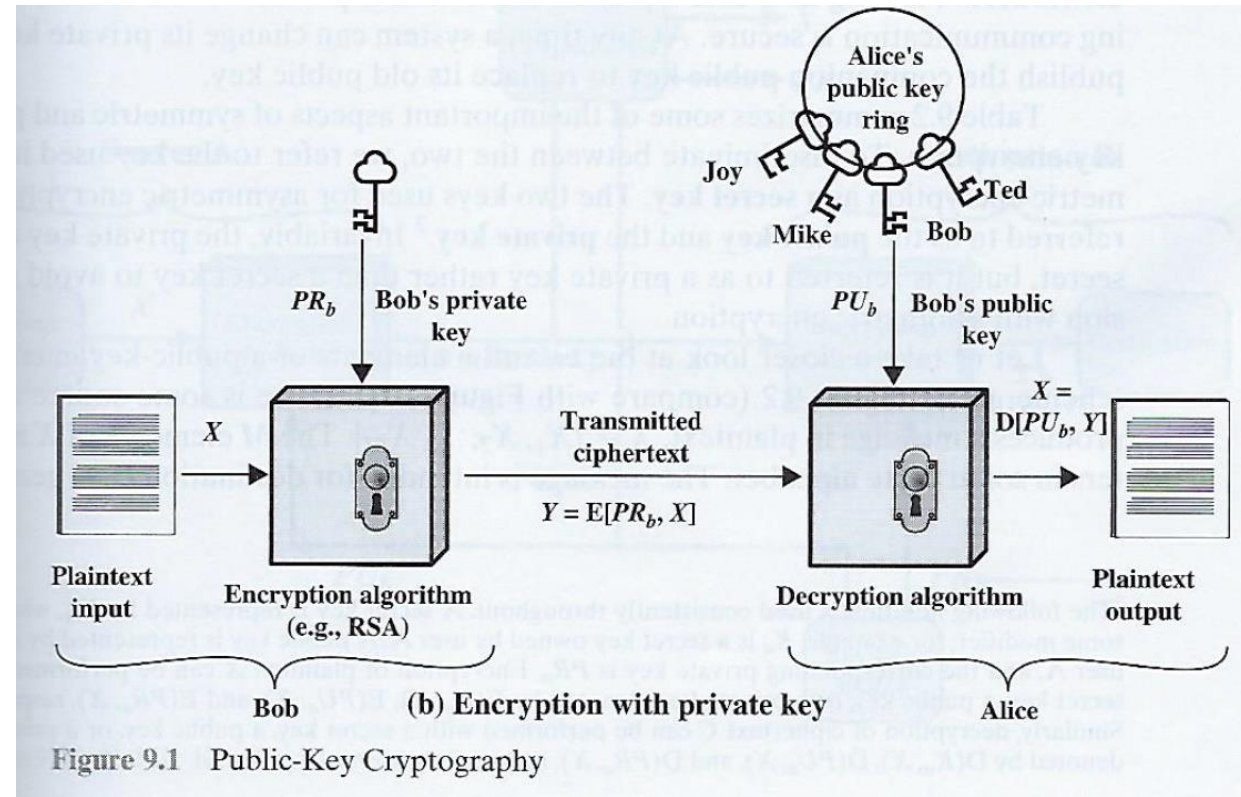
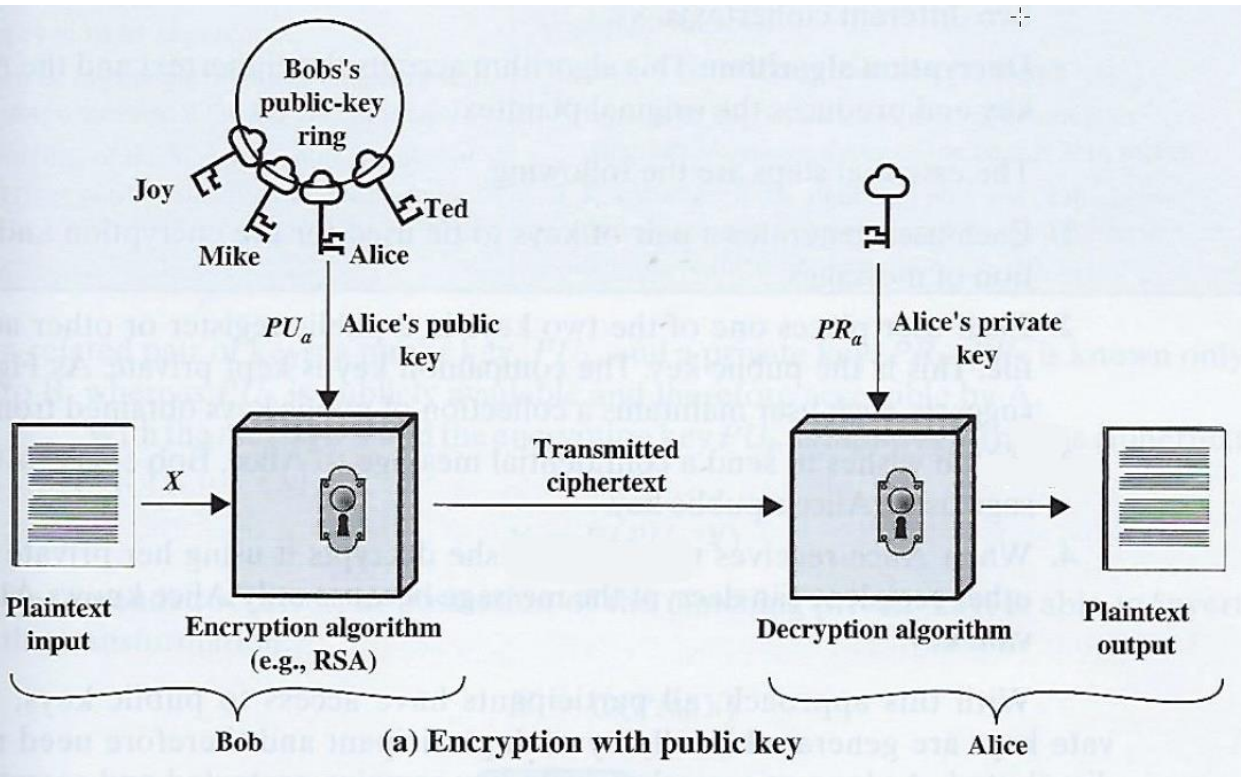

Stallings, W. (2014) Cryptography and Network Security

Agenda

- ✓ Cryptography terminology
- ✓ Symmetric key cryptography
 - ✓ Symmetric stream cryptography
 - ✓ Symmetric block cryptography
- ✓ Key sharing problem
- ✓ Public Key Cryptography
 - ✓ Diffie-Hellman algorithm: symmetric key generation through asynchronous cryptography
 - ✓ RSA algorithm
- Hybrid-cryptography
 - Perfect Forward Secrecy
- Case study 1

Hybrid Encryption (a.k.a. “digital envelope”)

Symmetric and asymmetric algorithms are often used together

- Public key cryptography’s asymmetric algorithm is used to create public and private keys for secure automated key distribution
- Symmetric algorithm is used to create secret keys for rapid encryption/decryption of bulk data

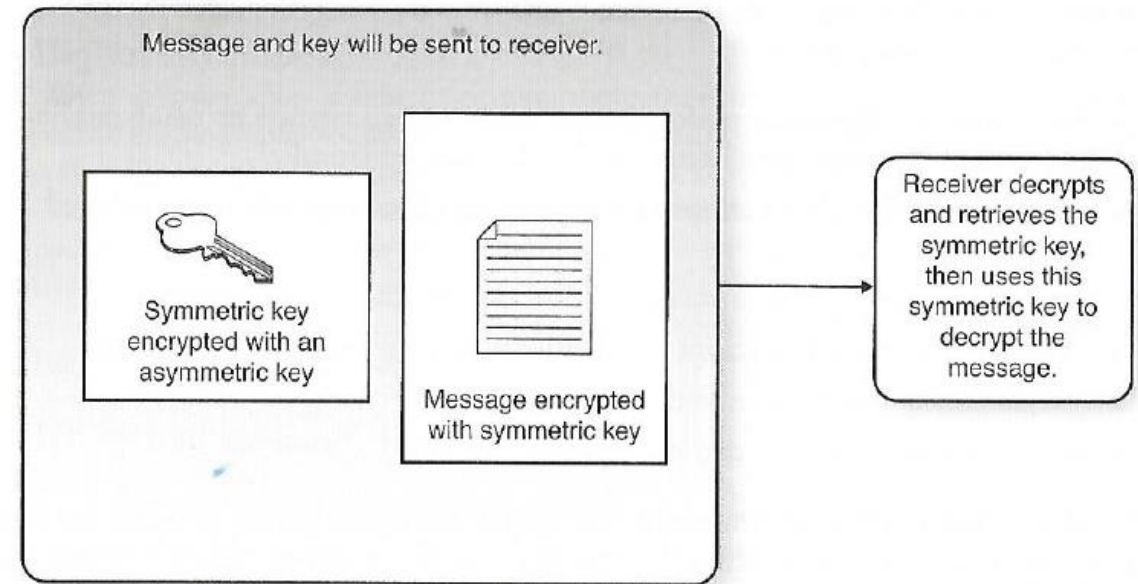

Hybrid Encryption

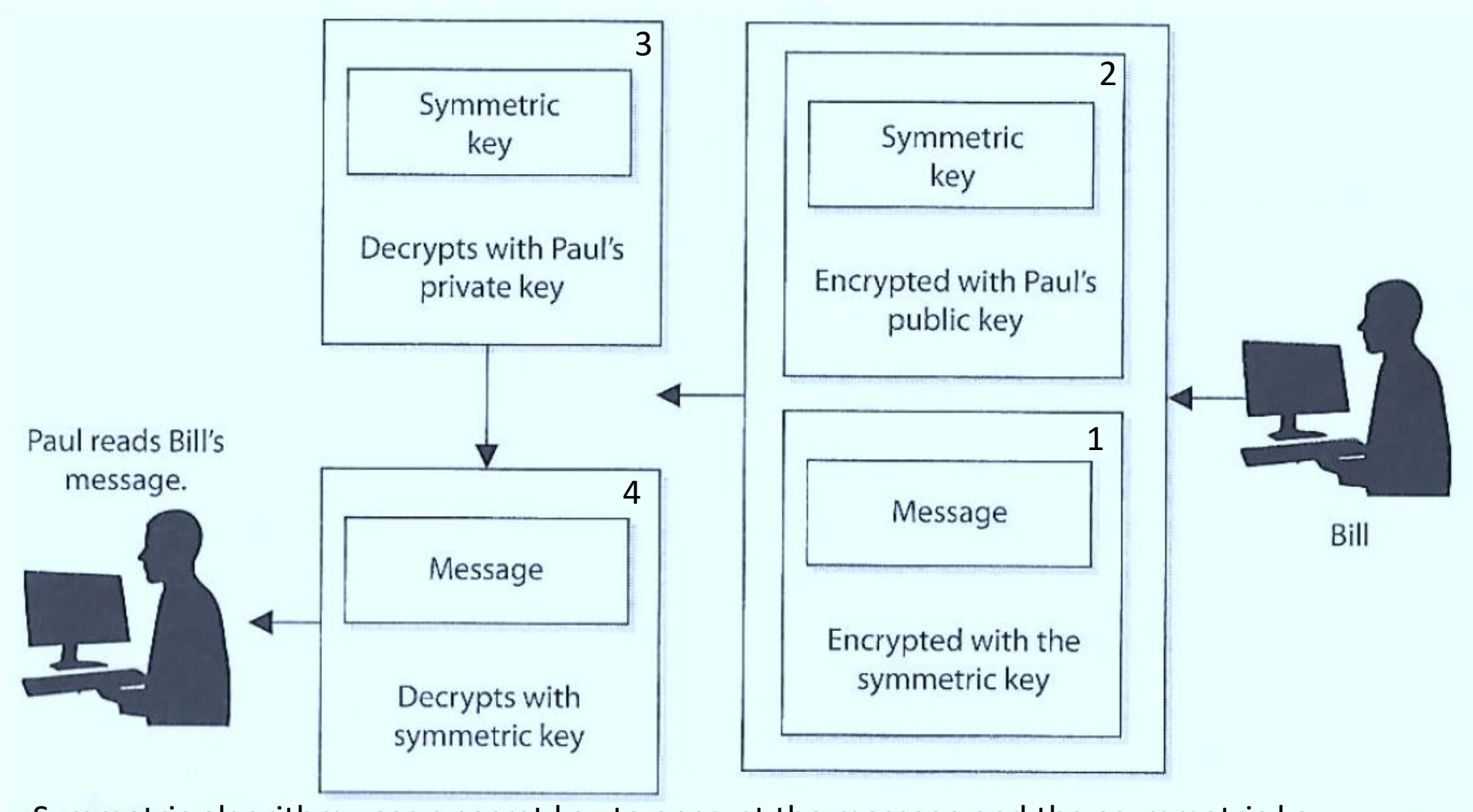

Symmetric algorithm uses a secret key to encrypt the message and the asymmetric key encrypts the secret key for transmission (SSL/TLS uses hybrid)

Session keys

Single-use symmetric keys used to encrypt messages between two users in an individual communication session

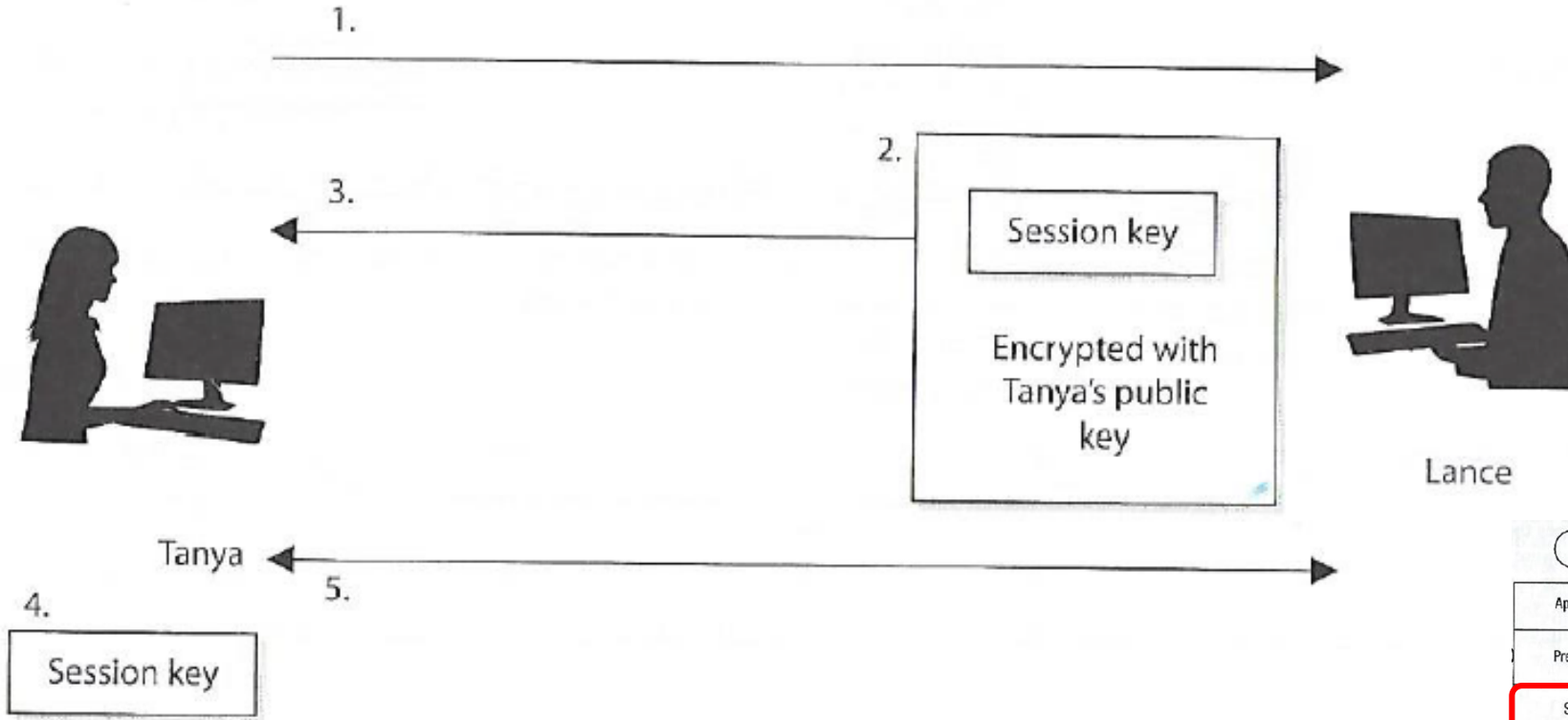

This is how secure web client applications communicate with server-side services

- 1) Tanya sends Lance her public key.
- 2) Lance generates a random session key and encrypts it using Tanya's public key.
- 3) Lance sends the session key, encrypted with Tanya's public key, to Tanya.
- 4) Tanya decrypts Lance's message with her private key and now has a copy of the session key.
- 5) Tanya and Lance use this session key to encrypt and decrypt messages to each other.

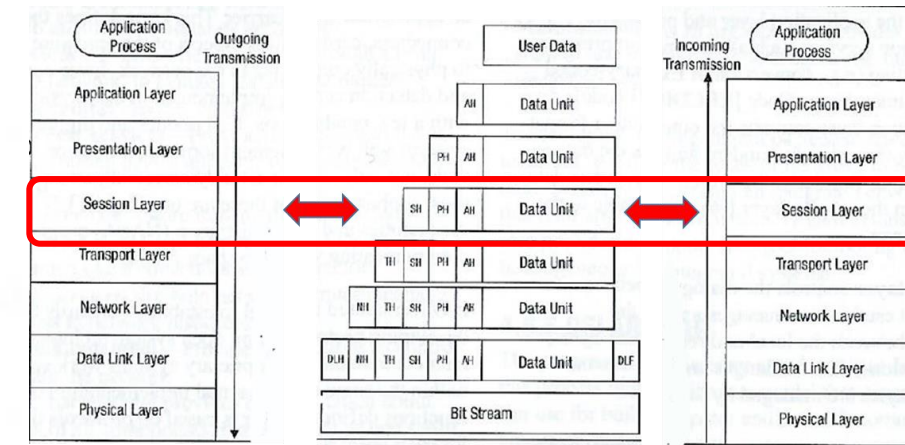

Perfect Forward Secrecy (PFS) or Forward Secrecy (FS)

Designed to prevent the compromise of a long-term secret key from affecting the confidentiality of past conversations

- Protects encrypted data recorded in past sessions against future attacks and compromises of private or secret keys
- Diffie-Hellman and RSA are used together to protect encrypted communications and sessions recorded in the past from being retrieved and decrypted in the future if long-term secret or private keys are compromised in the future

<https://www.wired.com/2016/11/what-is-perfect-forward-secrecy/>

Example of a simple instant messaging protocol employing forward secrecy:

1. Alice and Bob each generate a pair of long-term, asymmetric public and private keys, verification establishes confidence that the claimed owner of a public key is the actual owner
 2. Alice and Bob use a key exchange algorithm such as Diffie–Hellman, to securely agree on a short-term symmetric session key
 - *They use the asymmetric keys from step 1 only to authenticate one another during this process*
 3. Alice sends Bob a message, encrypting it with a symmetric cipher using the session key negotiated in step 2
 4. Bob decrypts Alice's message using the key negotiated in step 2
 5. The symmetric session key exchange process repeats for each new message sent, starting from step 2 (switching Alice and Bob's roles as sender/receiver as appropriate)
 - *Step 1 is never repeated*
- Forward secrecy is achieved by generating new session keys for each message
 - It ensures that past communications cannot be decrypted if one of the keys generated in an iteration of step 2 is compromised, since such a key is only used to encrypt a single message
 - It also ensures that past communications cannot be decrypted if the long-term private keys from step 1 are compromised
 - However, masquerading as Alice or Bob would be possible going forward if this occurred, possibly compromising all future messages

Perfect Forward Secrecy

- Forward secrecy is present in several major protocol implementations:
 - SSH
 - IPsec (RFC 2412) as an optional feature
 - Transport Layer Security (TLS)
 - Cipher suites based on Diffie–Hellman key exchange (DHE-RSA, DHE-DSA)
 - Elliptic curve Diffie–Hellman key exchange (ECDHE-RSA, ECDHE-ECDSA)
 - OpenSSL supports forward secrecy using elliptic curve Diffie–Hellman since V1.0
 - Off-the-Record Messaging, a cryptography protocol and library for many instant messaging clients

Perfect Forward Security in use...

Google Security Blog

The latest news and insights from Google on security and safety on the Internet

Protecting data for the long term with forward secrecy

November 22, 2011

Posted by Adam Langley, Security Team

Last year we introduced [HTTPS by default for Gmail](#) and [encrypted search](#). We're pleased to see that other major communications sites are following suit and deploying HTTPS in one form or another. We are now pushing forward by enabling [forward secrecy](#) by default.

Most major sites supporting HTTPS operate in a non-forward secret fashion, which runs the risk of retrospective decryption. In other words, an encrypted, unreadable email could be recorded while being delivered to your computer today. In ten years time, when computers are much faster, an adversary could break the server private key and

The new wireless encryption standard WPA3 uses PFS for all wireless clients

<https://security.googleblog.com/2011/11/protecting-data-for-long-term-with.html>

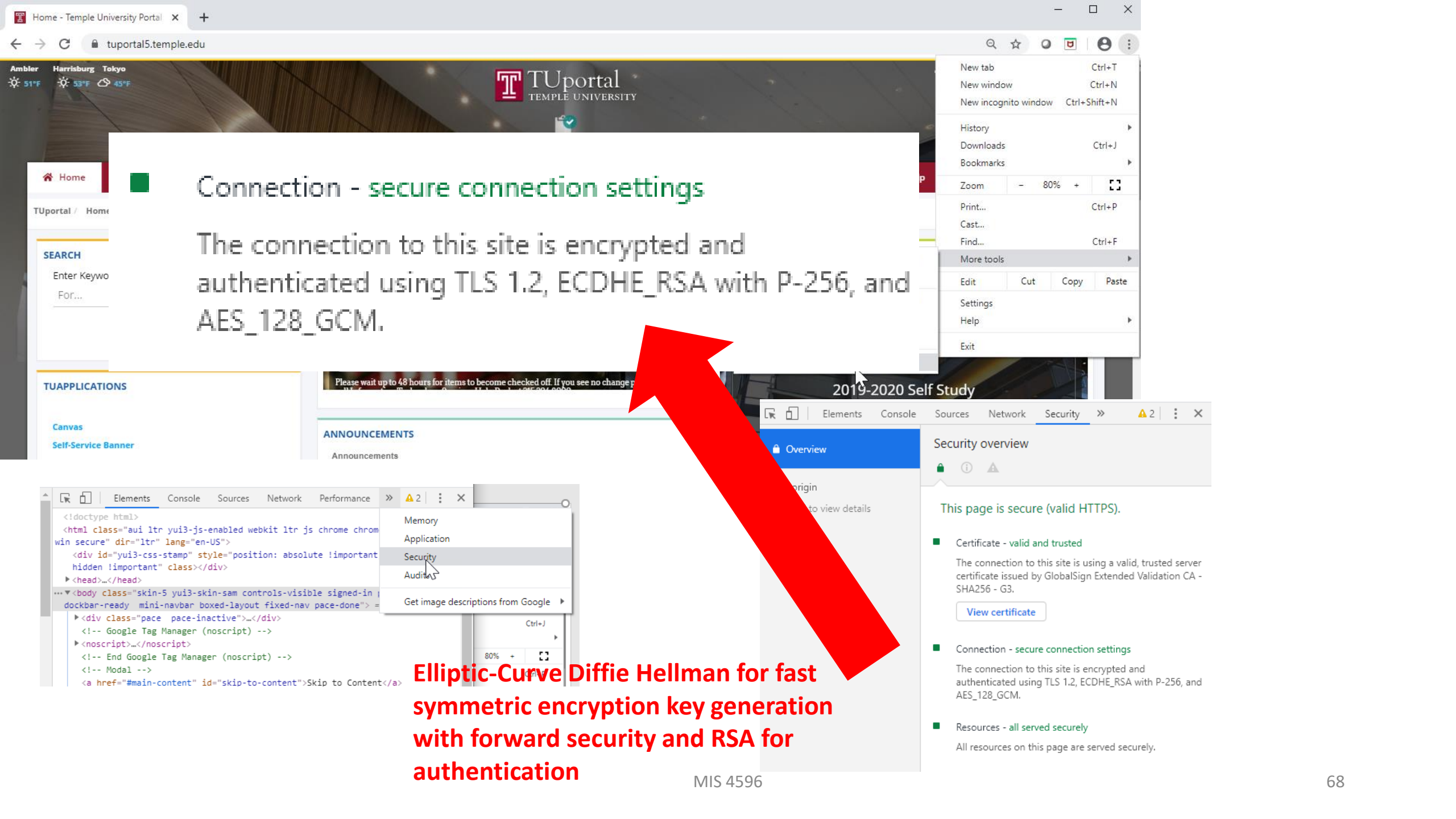

Connection - secure connection settings

The connection to this site is encrypted and authenticated using TLS 1.2, ECDHE_RSA with P-256, and AES_128_GCM.

Elliptic-Curve Diffie Hellman for fast symmetric encryption key generation with forward security and RSA for authentication

Insecure detection of the use of a static RSA encryption key

static-rsa.badssl.com

Security overview

This page is secure (valid HTTPS).

- Certificate - valid and trusted
The connection to this site is using a valid, trusted server certificate issued by DigiCert SHA2 Secure Server CA.
[View certificate](#)
- Resources - all served securely
All resources on this page are served securely.
- Connection - obsolete connection settings
The connection to this site is encrypted and authenticated using TLS 1.2, RSA, and AES_256_GCM.
 - RSA key exchange is obsolete. Enable an ECDHE-based cipher suite.

at

MIS 4596

This site uses a static RSA group for key exchange.

69

Growth in use of encryption

Percentage of Web Pages Loaded by Firefox Using HTTPS

(14-day moving average, source: [Firefox Telemetry](#))

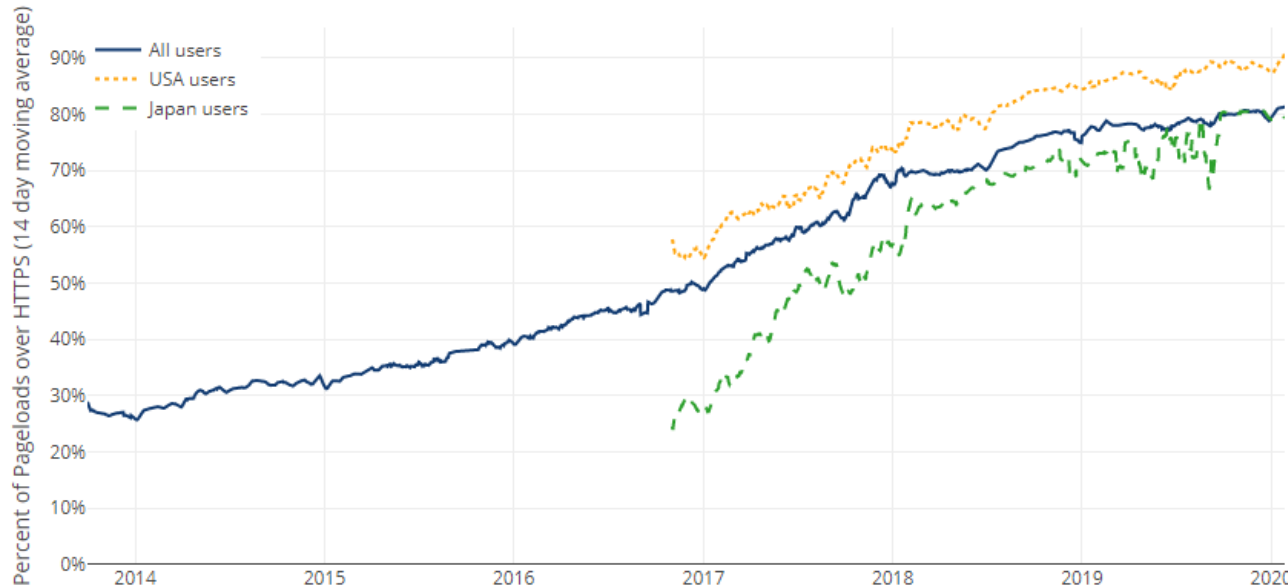

Encrypted traffic across Google

Security is a top priority at Google. We are investing and working to make sure that our sites and services provide modern HTTPS by default. Our goal is to achieve 100% encryption across our products and services. The chart below shows how we're doing across Google. For more details on the data, please [visit our FAQ](#).

[What is encryption?](#)

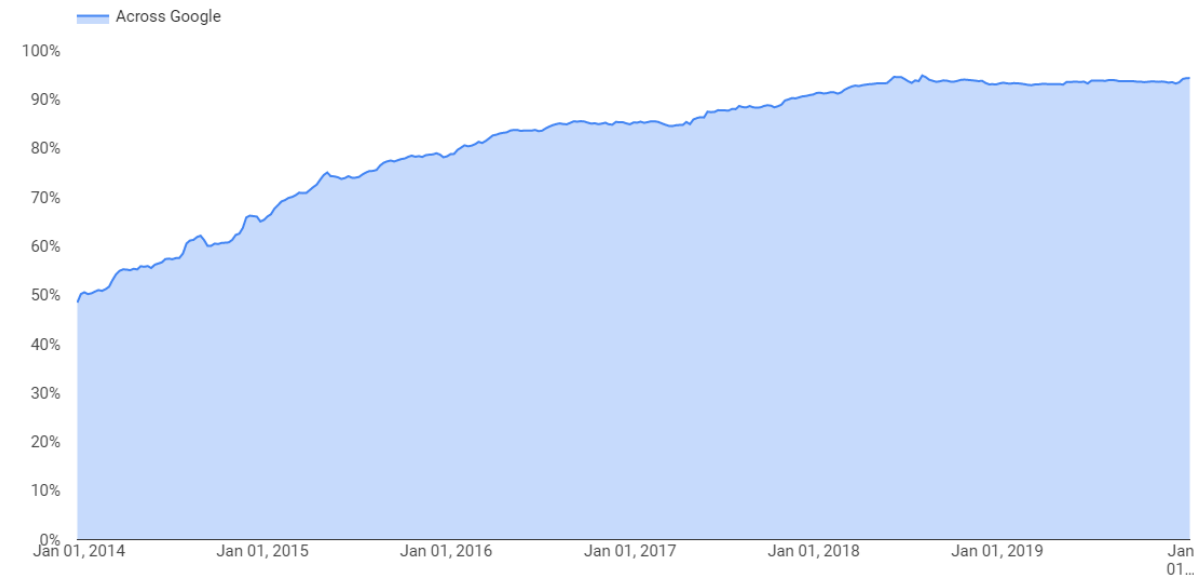

Today, more default encryption is used by consumers as ever before, as iPhones and Android phones come with encryption turned on by default, and the most of the world's website encrypted

Services of cryptosystems

- ✓ **Confidentiality** – Renders information unintelligible except by authorized entities
- ✓ **Authentication** – Verifies the identity of the user or system that created, requested or provided the information
- ✓ **Nonrepudiation** – Ensure the sender cannot deny sending the information
- **Integrity** – Data has not been altered in an unauthorized manner since it was created, transmitted, or stored

Agenda

- ✓ Cryptography terminology
- ✓ Symmetric key cryptography
 - ✓ Symmetric stream cryptography
 - ✓ Symmetric block cryptography
- ✓ Key sharing problem
- ✓ Public Key Cryptography
 - ✓ Diffie-Hellman algorithm: symmetric key generation through asynchronous cryptography
 - ✓ RSA algorithm
- ✓ Hybrid-cryptography
 - ✓ Perfect Forward Secrecy
- Case study 1

Draw a logical network diagram adding in graphical elements that illustrate the system boundary, interconnections and data flow

Draw a logical network diagram adding in graphical elements that illustrate the system boundary, interconnections and data flow

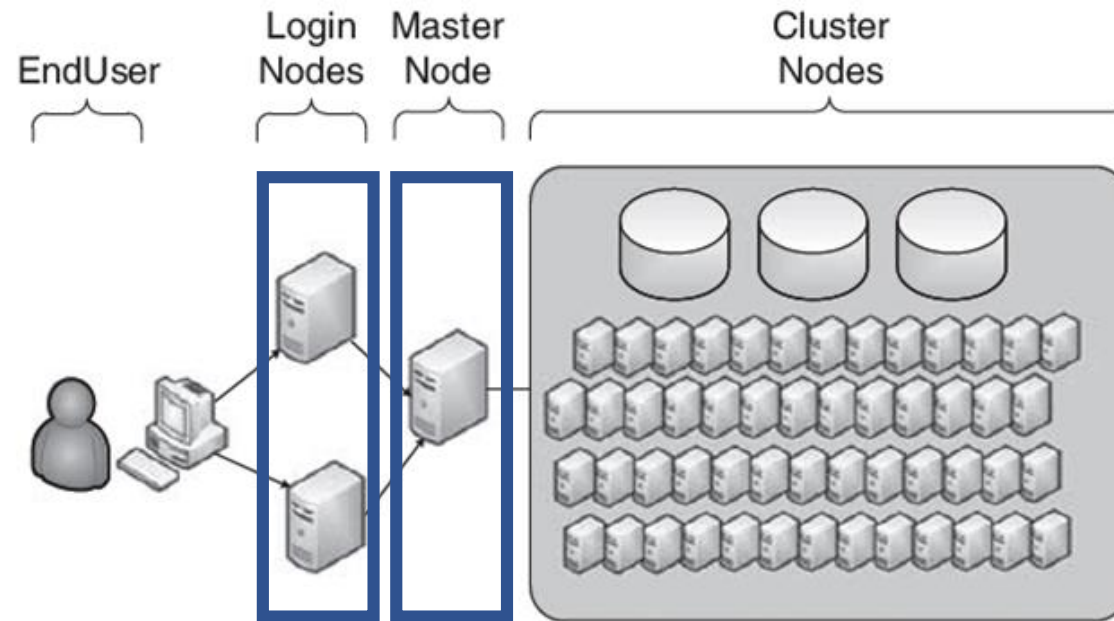

Figure 1 A typical grid architecture.

A High Performance Computing Cluster Under Attack: The Titan Incident

What was the specific attack vector(s) used by attacker:

1. ?
2. ?
3. ?
4. ?
5. ?
6. ?

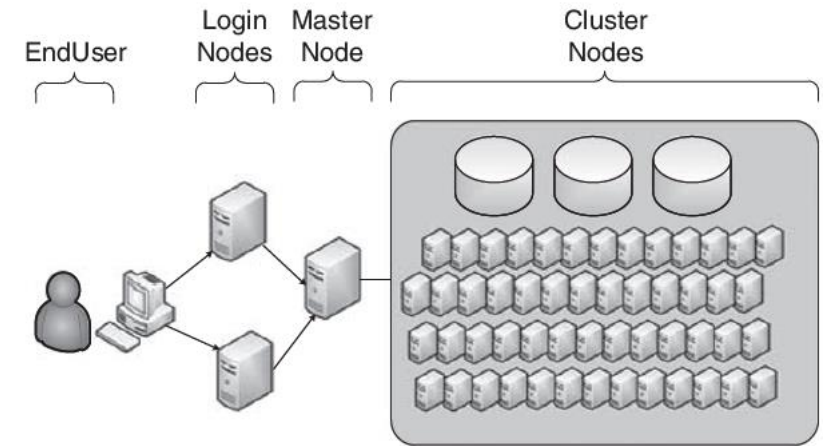

Figure 1 A typical grid architecture.

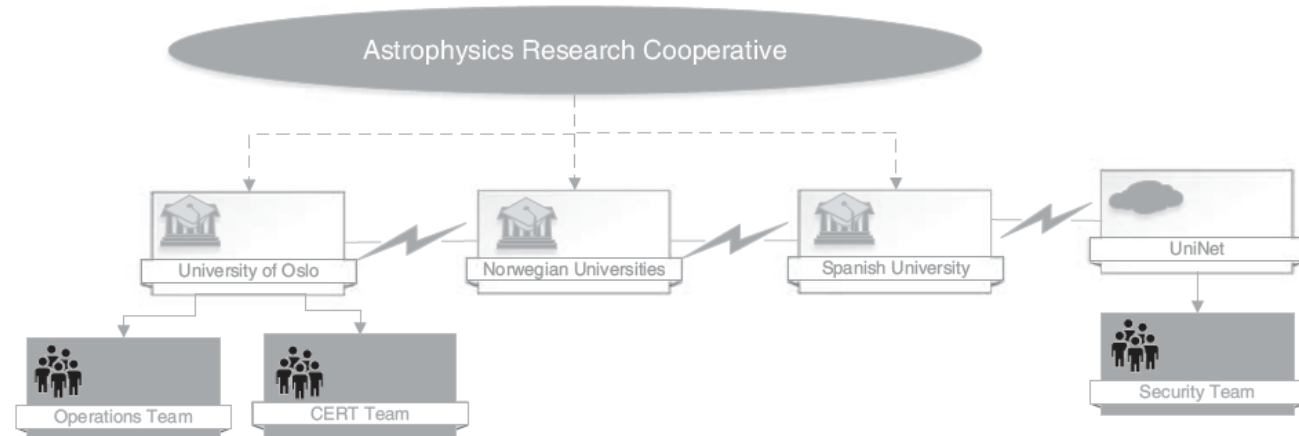

Figure 2 Geographic dispersion of Nordic DataGrid facility Tier-1 clusters.

A High Performance Computing Cluster Under Attack: The Titan Incident

Specific attack vector used by attacker:

1. Attacker obtained valid user names and password combinations from a system in Spain that had a research agreement with University of Oslo (UiO)
2. Attacker accessed the Titan cluster as a research user using the valid credentials that were “harvested” from the previously compromised system
3. The attacker used a local system exploit ([CVE-2010-3847](#)) to gain administrative privileges on the Titan system
4. Once administrative privileges were obtained, the attacker modified system files to collect the usernames and passwords of other end-users as they accessed the grid
5. The attacker created at least one “backdoor”, or method of accessing the system without relying on the compromised accounts
6. The newly stolen credentials were used to gain unauthorized access to other systems, and they may also have been sold on the black market

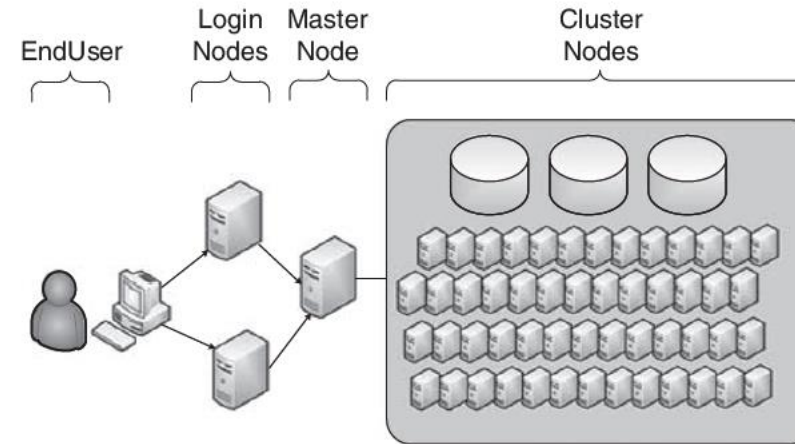

Figure 1 A typical grid architecture.

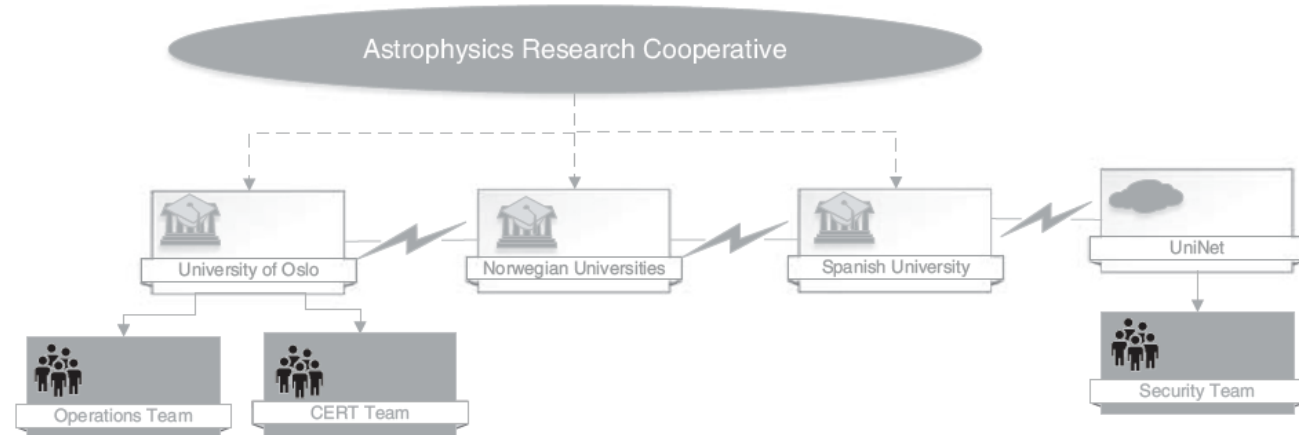

Figure 2 Geographic dispersion of Nordic DataGrid facility Tier-1 clusters.

What kind of failings permitted the attack's success?

- IT Governance
- End users
- Information technology services
- Information security
- Incident response

Where in the FedRAMP System Security Plan would you look for information to help you audit the security of the Titan Information System?



FEDRAMP SYSTEM SECURITY PLAN (SSP) HIGH BASELINE TEMPLATE

CSP Name | Information System Name

Version ## Date

TABLE OF CONTENTS

1.	INFORMATION SYSTEM NAME/TITLE	1
2.	INFORMATION SYSTEM CATEGORIZATION	1
2.1.	Information Types	1
2.2.	Security Objectives Categorization (FIPS 199)	3
2.3.	Digital Identity Determination	3
3.	INFORMATION SYSTEM OWNER	4
4.	AUTHORIZING OFFICIALS	4
5.	OTHER DESIGNATED CONTACTS	4
6.	ASSIGNMENT OF SECURITY RESPONSIBILITY	5
7.	INFORMATION SYSTEM OPERATIONAL STATUS	6
8.	INFORMATION SYSTEM TYPE	7
8.1.	Cloud Service Models	7
8.2.	Cloud Deployment Models	8
8.3.	Leveraged Authorizations	8
9.	GENERAL SYSTEM DESCRIPTION	9
9.1.	System Function or Purpose	9
9.2.	Information System Components and Boundaries	9
9.3.	Types of Users	10
9.4.	Network Architecture	11
10.	SYSTEM ENVIRONMENT AND INVENTORY	12
10.1.	Data Flow	12
10.2.	Ports, Protocols and Services	14
11.	SYSTEM INTERCONNECTIONS	15
12.	LAWS, REGULATIONS, STANDARDS AND GUIDANCE	17
12.1.	Applicable Laws and Regulations	17
12.2.	Applicable Standards and Guidance	17
13.	MINIMUM SECURITY CONTROLS	18

What should Margrete Raaum do next?

	Preventive Controls	Detective Controls	Corrective/Responsive Controls
Information Security			
Incident Response			
IT Governance			

How did the attacker attack the Titan cluster?

1. Attacker obtained valid user names and password combinations from a system in Spain that had a research agreement with University of Oslo (UiO)
2. Attacker accessed the Titan cluster as a research user using the valid credentials that were “harvested” from the previously compromised computer used by a researcher in Spain
3. The attacker used a local system exploit ([CVE-2010-3847](#)) to gain administrative privileges on the Titan system
4. Once administrative privileges were obtained, the attacker modified SSH system files to collect the usernames and passwords of other end-users as they accessed the grid

...the attacker modified SSH system files to collect the usernames and passwords of other end-users as they accessed the grid

Secure Shell (SSH) is a cryptographic network protocol for operating network services securely over an unsecured network. SSH provides a secure channel over an unsecured network in a client-server architecture, connecting an SSH client application with an SSH server

Common applications include remote command-line login and remote command execution, but any network service can be secured with SSH. The protocol specification distinguishes between two major versions, referred to as SSH-1 and SSH-2.

The most visible application of the protocol is for access to shell accounts on Unix-like operating systems, but is in limited use on Windows as well

SSH uses public-key cryptography to authenticate the remoted computer and allow it to authenticate the user

There are several ways to use SSH:

- One is to use automatically generated public-private key pairs to simply encrypt a network connection, and then use password authentication to log on
- Another is to use a manually generated public-private key pair to perform the authentication, allowing users or programs to log in without having to specify a password
 - In this scenario, anyone can produce a matching pair of different keys (public and private). The public key is placed on all computers that must allow access to the owner of the matching private key (the owner keeps the private key secret)

Remember... Session keys ?

Single-use symmetric keys used to encrypt messages between two users in an individual communication session

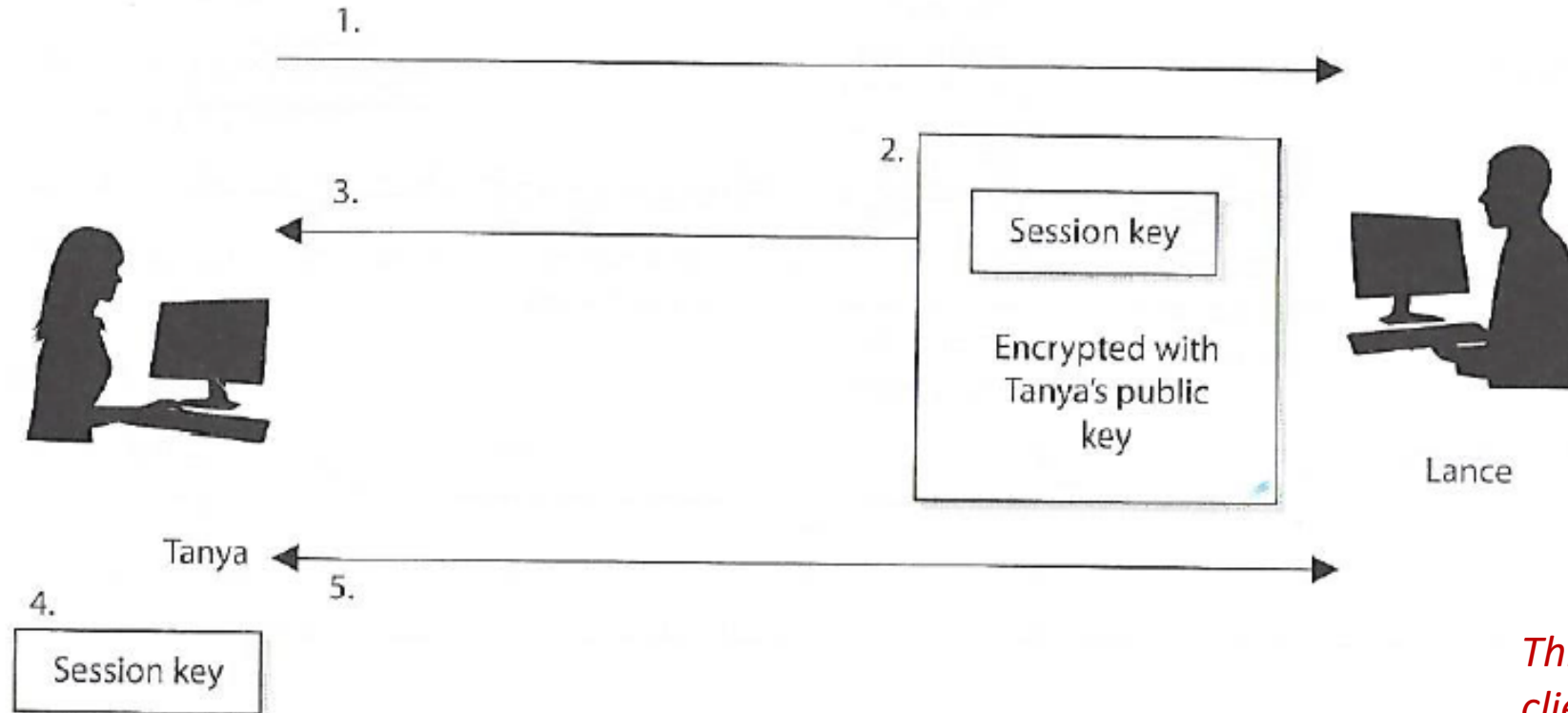

- 1) Tanya sends Lance her public key.
- 2) Lance generates a random session key and encrypts it using Tanya's public key.
- 3) Lance sends the session key, encrypted with Tanya's public key, to Tanya.
- 4) Tanya decrypts Lance's message with her private key and now has a copy of the session key.
- 5) Tanya and Lance use this session key to encrypt and decrypt messages to each other.

This is how secure web client applications communicate with server-side services

Where do you look for encryption related controls that could help Titan?

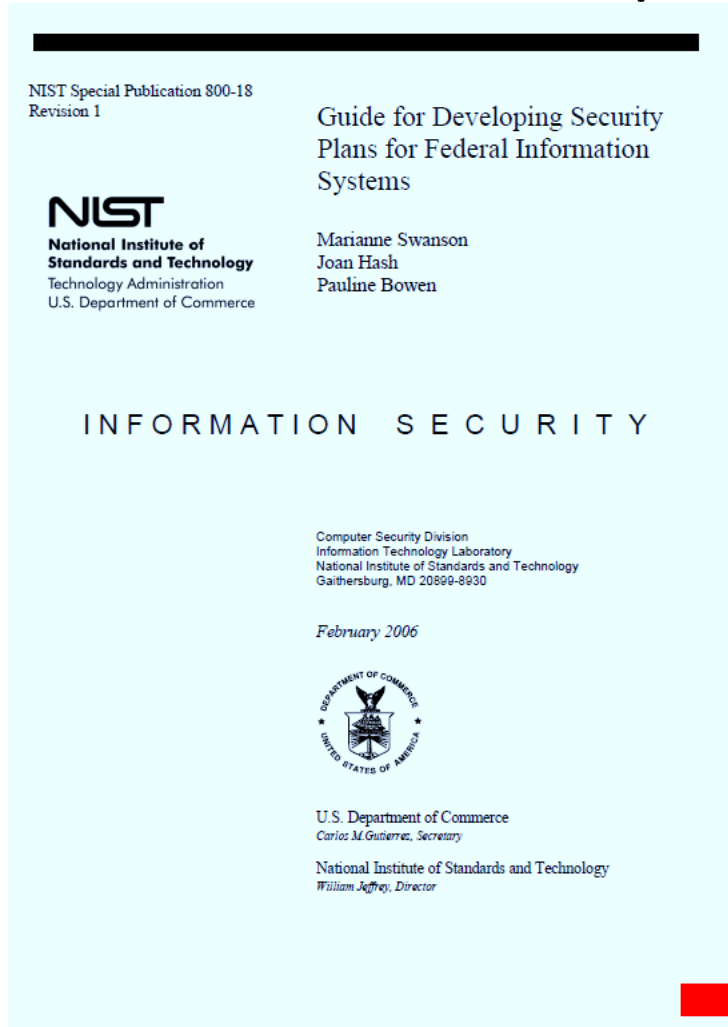

CLASS	FAMILY	IDENTIFIER
Management	Risk Assessment	RA
Management	Planning	PL
Management	System and Services Acquisition	SA
Management	Certification, Accreditation, and Security Assessments	CA
Operational	Personnel Security	PS
Operational	Physical and Environmental Protection	PE
Operational	Contingency Planning	CP
Operational	Configuration Management	CM
Operational	Maintenance	MA
Operational	System and Information Integrity	SI
Operational	Media Protection	MP
Operational	Incident Response	IR
Operational	Awareness and Training	AT
Technical	Identification and Authentication	IA
Technical	Access Control	AC
Technical	Audit and Accountability	AU
Technical	System and Communications Protection	SC

CNTL NO.	CONTROL NAME	PRIORITY	INITIAL CONTROL BASELINES		
			LOW	MOD	HIGH
System and Communications Protection					
SC-1	System and Communications Protection Policy and Procedures	P1	SC-1	SC-1	SC-1
SC-2	Application Partitioning	P1	Not Selected	SC-2	SC-2
SC-3	Security Function Isolation	P1	Not Selected	Not Selected	SC-3
SC-4	Information in Shared Resources	P1	Not Selected	SC-4	SC-4
SC-5	Denial of Service Protection	P1	SC-5	SC-5	SC-5
SC-6	Resource Availability	P0	Not Selected	Not Selected	Not Selected
SC-7	Boundary Protection	P1	SC-7	SC-7 (3) (4) (5) (7)	SC-7 (3) (4) (5) (7) (8) (18) (21)
SC-8	Transmission Confidentiality and Integrity	P1	Not Selected	SC-8 (1)	SC-8 (1)
SC-9	Withdrawn	---	---	---	---
SC-10	Network Disconnect	P2	Not Selected	SC-10	SC-10
SC-11	Trusted Path	P0	Not Selected	Not Selected	Not Selected
SC-12	Cryptographic Key Establishment and Management	P1	SC-12	SC-12	SC-12 (1)
SC-13	Cryptographic Protection	P1	SC-13	SC-13	SC-13
SC-14	Withdrawn	---	---	---	---
SC-15	Collaborative Computing Devices	P1	SC-15	SC-15	SC-15
SC-16	Transmission of Security Attributes	P0	Not Selected	Not Selected	Not Selected
SC-17	Public Key Infrastructure Certificates	P1	Not Selected	SC-17	SC-17
SC-18	Mobile Code	P2	Not Selected	SC-18	SC-18
SC-19	Voice Over Internet Protocol	P1	Not Selected	SC-19	SC-19
SC-20	Secure Name /Address Resolution Service (Authoritative Source)	P1	SC-20	SC-20	SC-20
SC-21	Secure Name /Address Resolution Service (Recursive or Caching Resolver)	P1	SC-21	SC-21	SC-21
SC-22	Architecture and Provisioning for Name/Address Resolution Service	P1	SC-22	SC-22	SC-22
SC-23	Session Authenticity	P1	Not Selected	SC-23	SC-23
SC-24	Fail in Known State	P1	Not Selected	Not Selected	SC-24
SC-28	Protection of Information at Rest	P1	Not Selected	SC-28	SC-28
SC-39	Process Isolation	P1	SC-39	SC-39	SC-39

SC-12 CRYPTOGRAPHIC KEY ESTABLISHMENT AND MANAGEMENT

Control: The organization establishes and manages cryptographic keys for required cryptography employed within the information system in accordance with [Assignment: organization-defined requirements for key generation, distribution, storage, access, and destruction].

Supplemental Guidance: Cryptographic key management and establishment can be performed using manual procedures or automated mechanisms with supporting manual procedures. Organizations define key management requirements in accordance with applicable federal laws, Executive Orders, directives, regulations, policies, standards, and guidance, specifying appropriate options, levels, and parameters. Organizations manage trust stores to ensure that only approved trust anchors are in such trust stores. This includes certificates with visibility external to organizational information systems and certificates related to the internal operations of systems. Related controls: SC-13, SC-17.

Control Enhancements:

- CRYPTOGRAPHIC KEY ESTABLISHMENT AND MANAGEMENT | AVAILABILITY**
The organization maintains availability of information in the event of the loss of cryptographic keys by users.
Supplemental Guidance: Escrowing of encryption keys is a common practice for ensuring availability in the event of loss of keys (e.g., due to forgotten passphrase).
- CRYPTOGRAPHIC KEY ESTABLISHMENT AND MANAGEMENT | SYMMETRIC KEYS**
The organization produces, controls, and distributes symmetric cryptographic keys using [Selection: NIST FIPS-compliant; NSA-approved] key management technology and processes.
- CRYPTOGRAPHIC KEY ESTABLISHMENT AND MANAGEMENT | ASYMMETRIC KEYS**
The organization produces, controls, and distributes asymmetric cryptographic keys using [Selection: NSA-approved key management technology and processes; approved PKI Class 3 certificates or prepositioned keying material; approved PKI Class 3 or Class 4 certificates and hardware security tokens that protect the user's private key].
- CRYPTOGRAPHIC KEY ESTABLISHMENT AND MANAGEMENT | PKI CERTIFICATES**
[Withdrawn: Incorporated into SC-12].
- CRYPTOGRAPHIC KEY ESTABLISHMENT AND MANAGEMENT | PKI CERTIFICATES / HARDWARE TOKENS**
[Withdrawn: Incorporated into SC-12].

References: NIST Special Publications 800-56, 800-57.

Priority and Baseline Allocation:

P1	LOW	SC-12	MOD	SC-12	HIGH	SC-12 (1)
----	-----	-------	-----	-------	------	-----------

CNTL NO.	CONTROL NAME	PRIORITY	INITIAL CONTROL BASELINES		
			LOW	MOD	HIGH
System and Communications Protection					
SC-1	System and Communications Protection Policy and Procedures	P1	SC-1	SC-1	SC-1
SC-2	Application Partitioning	P1	Not Selected	SC-2	SC-2
SC-3	Security Function Isolation	P1	Not Selected	Not Selected	SC-3
SC-4	Information in Shared Resources	P1	Not Selected	SC-4	SC-4
SC-5	Denial of Service Protection	P1	SC-5	SC-5	SC-5
SC-6	Resource Availability	P0	Not Selected	Not Selected	Not Selected
SC-7	Boundary Protection	P1	SC-7	SC-7 (3) (4) (5) (7)	SC-7 (3) (4) (5) (7) (8) (18) (21)
SC-8	Transmission Confidentiality and Integrity	P1	Not Selected	SC-8 (1)	SC-8 (1)
SC-9	Withdrawn	---	---	---	---
SC-10	Network Disconnect	P2	Not Selected	SC-10	SC-10
SC-11	Trusted Path	P0	Not Selected	Not Selected	Not Selected
SC-12	Cryptographic Key Establishment and Management	P1	SC-12	SC-12	SC-12 (1)
SC-13	Cryptographic Protection	P1	SC-13	SC-13	SC-13
SC-14	Withdrawn	---	---	---	---
SC-15	Collaborative Computing Devices	P1	SC-15	SC-15	SC-15
SC-16	Transmission of Security Attributes	P0	Not Selected	Not Selected	Not Selected
SC-17	Public Key Infrastructure Certificates	P1	Not Selected	SC-17	SC-17
SC-18	Mobile Code	P2	Not Selected	SC-18	SC-18
SC-19	Voice Over Internet Protocol	P1	Not Selected	SC-19	SC-19
SC-20	Secure Name /Address Resolution Service (Authoritative Source)	P1	SC-20	SC-20	SC-20
SC-21	Secure Name /Address Resolution Service (Recursive or Caching Resolver)	P1	SC-21	SC-21	SC-21
SC-22	Architecture and Provisioning for Name/Address Resolution Service	P1	SC-22	SC-22	SC-22
SC-23	Session Authenticity	P1	Not Selected	SC-23	SC-23
SC-24	Fail in Known State	P1	Not Selected	Not Selected	SC-24
SC-28	Protection of Information at Rest	P1	Not Selected	SC-28	SC-28
SC-39	Process Isolation	P1	SC-39	SC-39	SC-39

SC-13 CRYPTOGRAPHIC PROTECTION

Control: The information system implements [Assignment: organization-defined cryptographic uses and type of cryptography required for each use] in accordance with applicable federal laws, Executive Orders, directives, policies, regulations, and standards.

Supplemental Guidance: Cryptography can be employed to support a variety of security solutions including, for example, the protection of classified and Controlled Unclassified Information, the provision of digital signatures, and the enforcement of information separation when authorized individuals have the necessary clearances for such information but lack the necessary formal access approvals. Cryptography can also be used to support random number generation and hash generation. Generally applicable cryptographic standards include FIPS-validated cryptography and NSA-approved cryptography. This control does not impose any requirements on organizations to use cryptography. However, if cryptography is required based on the selection of other security controls, organizations define each type of cryptographic use and the type of cryptography required (e.g., protection of classified information: NSA-approved cryptography; provision of digital signatures: FIPS-validated cryptography). Related controls: AC-2, AC-3, AC-7, AC-17, AC-18, AU-9, AU-10, CM-11, CP-9, IA-3, IA-7, MA-4, MP-2, MP-4, MP-5, SA-4, SC-8, SC-12, SC-28, SI-7.

Control Enhancements: None.

- (1) CRYPTOGRAPHIC PROTECTION | FIPS-VALIDATED CRYPTOGRAPHY
[Withdrawn: Incorporated into SC-13].
- (2) CRYPTOGRAPHIC PROTECTION | NSA-APPROVED CRYPTOGRAPHY
[Withdrawn: Incorporated into SC-13].
- (3) CRYPTOGRAPHIC PROTECTION | INDIVIDUALS WITHOUT FORMAL ACCESS APPROVALS
[Withdrawn: Incorporated into SC-13].
- (4) CRYPTOGRAPHIC PROTECTION | DIGITAL SIGNATURES
[Withdrawn: Incorporated into SC-13].

References: FIPS Publication 140; Web: <http://csrc.nist.gov/cryptval>, <http://www.cnss.gov>.

Priority and Baseline Allocation:

P1	LOW SC-13	MOD SC-13	HIGH SC-13
----	-----------	-----------	------------

SC-13 CRYPTOGRAPHIC PROTECTION

Control: The information system implements [*Assignment: organization-defined cryptographic uses and type of cryptography required for each use*] in accordance with applicable federal laws, Executive Orders, directives, policies, regulations, and standards.

Supplemental Guidance: Cryptography can be employed to support a variety of security solutions including, for example, the protection of classified and Controlled Unclassified Information, the provision of digital signatures, and the enforcement of information separation when authorized individuals have the necessary clearances for such information but lack the necessary formal access approvals. Cryptography can also be used to support random number generation and hash generation. Generally applicable cryptographic standards include FIPS-validated cryptography and NSA-approved cryptography. This control does not impose any requirements on organizations to use cryptography. However, if cryptography is required based on the selection of other security controls, organizations define each type of cryptographic use and the type of cryptography required (e.g., protection of classified information: NSA-approved cryptography; provision of digital signatures: FIPS-validated cryptography). Related controls: AC-2, AC-3, AC-7, AC-17, AC-18, AU-9, AU-10, CM-11, CP-9, IA-3, IA-7, MA-4, MP-2, MP-4, MP-5, SA-4, SC-8, SC-12, SC-28, SI-7.

Control Enhancements: None.

- (1) CRYPTOGRAPHIC PROTECTION | FIPS-VALIDATED CRYPTOGRAPHY
[Withdrawn: Incorporated into SC-13].
- (2) CRYPTOGRAPHIC PROTECTION | NSA-APPROVED CRYPTOGRAPHY
[Withdrawn: Incorporated into SC-13].
- (3) CRYPTOGRAPHIC PROTECTION | INDIVIDUALS WITHOUT FORMAL ACCESS APPROVALS
[Withdrawn: Incorporated into SC-13].
- (4) CRYPTOGRAPHIC PROTECTION | DIGITAL SIGNATURES
[Withdrawn: Incorporated into SC-13].

References: FIPS Publication 140; Web: <http://csrc.nist.gov/cryptval>, <http://www.cnss.gov>.

Priority and Baseline Allocation:

P1	LOW SC-13	MOD SC-13	HIGH SC-13
----	-----------	-----------	------------

CLASS	FAMILY	IDENTIFIER
Management	Risk Assessment	RA
Management	Planning	PL
Management	System and Services Acquisition	SA
Management	Certification, Accreditation, and Security Assessments	CA
Operational	Personnel Security	PS
Operational	Physical and Environmental Protection	PE
Operational	Contingency Planning	CP
Operational	Configuration Management	CM
Operational	Maintenance	MA
Operational	System and Information Integrity	SI
Operational	Media Protection	MP
Operational	Incident Response	IR
Operational	Awareness and Training	AT
Technical	Identification and Authentication	IA
Technical	Access Control	AC
Technical	Audit and Accountability	AU
Technical	System and Communications Protection	SC

Where do you document this information in your SSP?



FEDRAMP SYSTEM SECURITY PLAN (SSP) HIGH BASELINE TEMPLATE

CSP Name | Information System Name

Version #.## Date

TABLE OF CONTENTS

1.	INFORMATION SYSTEM NAME/TITLE	1
2.	INFORMATION SYSTEM CATEGORIZATION	1
2.1.	Information Types	1
2.2.	Security Objectives Categorization (FIPS 199).....	3
2.3.	Digital Identity Determination	3
3.	INFORMATION SYSTEM OWNER	4
4.	AUTHORIZING OFFICIALS	4
5.	OTHER DESIGNATED CONTACTS	4
6.	ASSIGNMENT OF SECURITY RESPONSIBILITY	5
7.	INFORMATION SYSTEM OPERATIONAL STATUS.....	6
8.	INFORMATION SYSTEM TYPE	7
8.1.	Cloud Service Models.....	7
8.2.	Cloud Deployment Models.....	8
8.3.	Leveraged Authorizations	8
9.	GENERAL SYSTEM DESCRIPTION.....	9
9.1.	System Function or Purpose.....	9
9.2.	Information System Components and Boundaries	9
9.3.	Types of Users	10
9.4.	Network Architecture	11
10.	SYSTEM ENVIRONMENT AND INVENTORY.....	12
10.1.	Data Flow	12
10.2.	Ports, Protocols and Services	14
11.	SYSTEM INTERCONNECTIONS.....	15
12.	LAWS, REGULATIONS, STANDARDS AND GUIDANCE.....	17
12.1.	Applicable Laws and Regulations	17
12.2.	Applicable Standards and Guidance	17
13.	MINIMUM SECURITY CONTROLS	18
13.1.	Access Control (AC).....	25
	AC-1 Access Control Policy and Procedures Requirements (H)	25
	AC-2 Account Management (H).....	26
	AC-2 (1) Control Enhancement (M) (H)	27
	AC-2 (2) Control Enhancement (H).....	28
	AC-2 (3) Control Enhancement (H).....	29
	AC-2 (4) Control Enhancement (H).....	30
	AC-2 (5) Control Enhancement (H).....	31
	AC-2 (7) Control Enhancement (H).....	31
	AC-2 (9) Control Enhancement (H).....	32
	AC-2 (10) Control Enhancement (M) (H)	33
	AC-2 (11) Control Enhancement (H).....	34
	AC-2 (12) Control Enhancement (H).....	35

FedRAMP 0100110010001010 0001001010010010000010 0011010101000010011101010 | v

Controlled Unclassified Information

FEDRAMP SYSTEM SECURITY PLAN (SSP) HIGH BASELINE TEMPLATE

Cloud Service Provider Name
 Information System Name
 Version #
 Version Date



CONTROLLED UNCLASSIFIED INFORMATION

FEDRAMP SYSTEM SECURITY PLAN (SSP) HIGH BASELINE TEMPLATE

CSP Name | Information System Name

Version ##, Date

SA-9 (5) Control Enhancement (M) (H).....	315
SA-10 Developer Configuration Management (M) (H)	316
SA-10 (1) Control Enhancement (M) (H).....	317
SA-11 Developer Security Testing and Evaluation (M) (H).....	318
SA-11 (1) Control Enhancement (M) (H).....	319
SA-11 (2) Control Enhancement (M) (H).....	320
SA-11 (8) Control Enhancement (M) (H).....	321
SA-12 Supply Chain Protection (H)	322
SA-15 Development Process, Standards, and Tools (H).....	322
SA-16 Developer-Provided Training (H).....	324
SA-17 Developer Security Architecture and Design (H).....	324
13.16. System and Communications Protection (SC).....	325
SC-1 System and Communications Protection Policy and Procedures (H)	325
SC-2 Application Partitioning (M) (H).....	326
SC-3 Security Function Isolation (H)	327
SC-4 Information in Shared Resources (M) (H)	328
SC-5 Denial of Service Protection (L) (M) (H).....	329
SC-6 Resource Availability (M) (H)	329
SC-7 Boundary Protection (L) (M) (H)	330
SC-7 (3) Control Enhancement (M) (H).....	331
SC-7 (4) Control Enhancement (H)	332
SC-7 (5) Control Enhancement (M) (H).....	333
SC-7 (7) Control Enhancement (M) (H).....	334
SC-7 (8) Control Enhancement (M) (H).....	335
SC-7 (10) Control Enhancement (H)	335
SC-7 (12) Control Enhancement (H)	336
SC-7 (13) Control Enhancement (H)	337
SC-7 (18) Control Enhancement (M) (H).....	338
SC-7 (20) Control Enhancement (H)	339
SC-7 (21) Control Enhancement (H)	339
SC-8 Transmission confidentiality and Integrity (M) (H).....	340
SC-8 (1) Control Enhancement (M) (H).....	341
SC-10 Network Disconnect (H)	342
SC-12 Cryptographic Key Establishment & Management (L) (M) (H)	343
SC-12 (1) Control Enhancement (H)	344
SC-12 (2) Control Enhancement (M) (H).....	344
SC-12 (3) Control Enhancement (M) (H).....	345
SC-13 Use of Cryptography (L) (M) (H)	346
SC-15 Collaborative Computing Devices (M) (H)	347
SC-17 Public Key Infrastructure Certificates (M) (H).....	348
SC-18 Mobile Code (M) (H)	349
SC-19 Voice Over Internet Protocol (M) (H)	350
SC-20 Secure Name / Address Resolution Service (Authoritative Source) (L) (M) (H).....	351
SC-21 Secure Name / Address Resolution Service (Recursive or Caching Resolver) (L) (M) (H)	352
SC-22 Architecture and Provisioning for Name / Address Resolution Service (L) (M) (H)	353
SC-23 Session Authenticity (M) (H).....	353



SC-12 Cryptographic Key Establishment & Management (L) (M) (H)

The organization establishes and manages cryptographic keys for required cryptography employed within the information system in accordance with [Assignment: organization-defined requirements for key generation, distribution, storage, access, and destruction].

SC-12 Additional FedRAMP Requirements and Guidance:

Guidance: Federally approved and validated cryptography.

SC-12	Control Summary Information
Responsible Role:	
Parameter SC-12:	
Implementation Status (check all that apply):	
<input type="checkbox"/> Implemented <input type="checkbox"/> Partially implemented <input type="checkbox"/> Planned <input type="checkbox"/> Alternative implementation <input type="checkbox"/> Not applicable	
Control Origination (check all that apply):	
<input type="checkbox"/> Service Provider Corporate <input type="checkbox"/> Service Provider System Specific <input type="checkbox"/> Service Provider Hybrid (Corporate and System Specific) <input type="checkbox"/> Configured by Customer (Customer System Specific) <input type="checkbox"/> Provided by Customer (Customer System Specific) <input type="checkbox"/> Shared (Service Provider and Customer Responsibility) <input type="checkbox"/> Inherited from pre-existing FedRAMP Authorization for Click here to enter text. , Date of Authorization	

SC-12 What is the solution and how is it implemented?

FEDRAMP SYSTEM SECURITY PLAN (SSP) HIGH BASELINE TEMPLATE

Cloud Service Provider Name
 Information System Name
 Version #
 Version Date



CONTROLLED UNCLASSIFIED INFORMATION

SA-9 (5) Control Enhancement (M) (H).....	315
SA-10 Developer Configuration Management (M) (H)	316
SA-10 (1) Control Enhancement (M) (H)	317
SA-11 Developer Security Testing and Evaluation (M) (H).....	318
SA-11 (1) Control Enhancement (M) (H).....	319
SA-11 (2) Control Enhancement (M) (H).....	320
SA-11 (8) Control Enhancement (M) (H).....	321
SA-12 Supply Chain Protection (H)	322
SA-15 Development Process, Standards, and Tools (H).....	322
SA-16 Developer-Provided Training (H).....	324
SA-17 Developer Security Architecture and Design (H).....	324
13.16. System and Communications Protection (SC).....	325
SC-1 System and Communications Protection Policy and Procedures (H)	325
SC-2 Application Partitioning (M) (H).....	326
SC-3 Security Function Isolation (H)	327
SC-4 Information in Shared Resources (M) (H)	328
SC-5 Denial of Service Protection (L) (M) (H).....	329
SC-6 Resource Availability (M) (H)	329
SC-7 Boundary Protection (L) (M) (H)	330
SC-7 (3) Control Enhancement (M) (H).....	331
SC-7 (4) Control Enhancement (H)	332
SC-7 (5) Control Enhancement (M) (H).....	333
SC-7 (7) Control Enhancement (M) (H).....	334
SC-7 (8) Control Enhancement (M) (H).....	335
SC-7 (10) Control Enhancement (H)	335
SC-7 (12) Control Enhancement (H)	336
SC-7 (13) Control Enhancement (H)	337
SC-7 (18) Control Enhancement (M) (H).....	338
SC-7 (20) Control Enhancement (H)	339
SC-7 (21) Control Enhancement (H)	339
SC-8 Transmission confidentiality and Integrity (M) (H).....	340
SC-8 (1) Control Enhancement (M) (H).....	341
SC-10 Network Disconnect (H)	342
SC-12 Cryptographic Key Establishment & Management (L) (M) (H)	343
SC-12 (1) Control Enhancement (H)	344
SC-12 (2) Control Enhancement (M) (H).....	344
SC-12 (3) Control Enhancement (M) (H).....	345
SC-13 Use of Cryptography (L) (M) (H)	346
SC-15 Collaborative Computing Devices (M) (H)	347
SC-17 Public Key Infrastructure Certificates (M) (H).....	348
SC-18 Mobile Code (M) (H)	349
SC-19 Voice Over Internet Protocol (M) (H)	350
SC-20 Secure Name / Address Resolution Service (Authoritative Source) (L) (M) (H).....	351
SC-21 Secure Name / Address Resolution Service (Recursive or Caching Resolver) (L) (M) (H).....	352
SC-22 Architecture and Provisioning for Name / Address Resolution Service (L) (M) (H).....	353
SC-23 Session Authenticity (M) (H).....	353



SC-12 (1) CONTROL ENHANCEMENT (H)

The organization maintains availability of information in the event of the loss of cryptographic keys by users.

SC-12 (2) CONTROL ENHANCEMENT (M) (H)

The organization produces, controls, and distributes symmetric cryptographic keys using [FedRAMP Selection: NIST FIPS-compliant] key management technology and processes.

SC-12 (3) CONTROL ENHANCEMENT (M) (H)

The organization produces, controls, and distributes asymmetric cryptographic keys using [Selection: NSA-approved key management technology and processes; approved PKI Class 3 certificates or prepositioned keying material; approved PKI Class 3 or Class 4 certificates and hardware security tokens that protect the user's private key].

SC-13 Use of Cryptography (L) (M) (H)

The information system implements [FedRAMP Assignment: FIPS-validated or NSA-approved cryptography] in accordance with applicable federal laws, Executive Orders, directives, policies, regulations, and standards.

Quiz

Which control is the BEST way to ensure that the data in a file have not been changed during transmission?

- a) Reasonableness check
- b) Parity bits
- c) Hash values
- d) Check digits

The PRIMARY reason for using digital signatures is to ensure data:

- a) confidentiality
- b) integrity
- c) availability
- d) Timeliness

Which of the following provides the GREATEST assurance for database password encryption?

- a) Secure hash algorithm-256 (SHA-256)
- b) Advanced encryption standard (AES)
- c) Secure Shell (SSH)
- d) Triple data encryption standard (DES)

Email message authenticity and confidentiality is BEST achieved by signing the message using the:

- a) Sender's private key and encrypting the message using the receiver's public key
- b) Sender's public key and encrypting the message using the receiver's private key
- c) Receiver's private key and encrypting the message using the sender's public key
- d) Receiver's public key and encrypting the message using the sender's private key

Agenda

- ✓ Cryptography terminology
- ✓ Symmetric key cryptography
 - ✓ Symmetric stream cryptography
 - ✓ Symmetric block cryptography
- ✓ Key sharing problem
- ✓ Public Key Cryptography
 - ✓ Diffie-Hellman algorithm: symmetric key generation through asynchronous cryptography
 - ✓ RSA algorithm
- ✓ Hybrid-cryptography
 - ✓ Perfect Forward Secrecy
- Case study 1

Quick Review: One-way Hash

- Assures message **integrity**
- A function that takes a variable-length string (i.e. message) and produces a fixed-length value called a hash value
- Does not use keys

1. Sender puts message through hashing function
2. Message digest generated
3. Message digest appended to the message
4. Sender sends message to receiver
5. Receiver puts message through hashing function
6. Receiver generates message digest value
7. Receiver compares the two message digests values. If they are the same, the message has not been altered

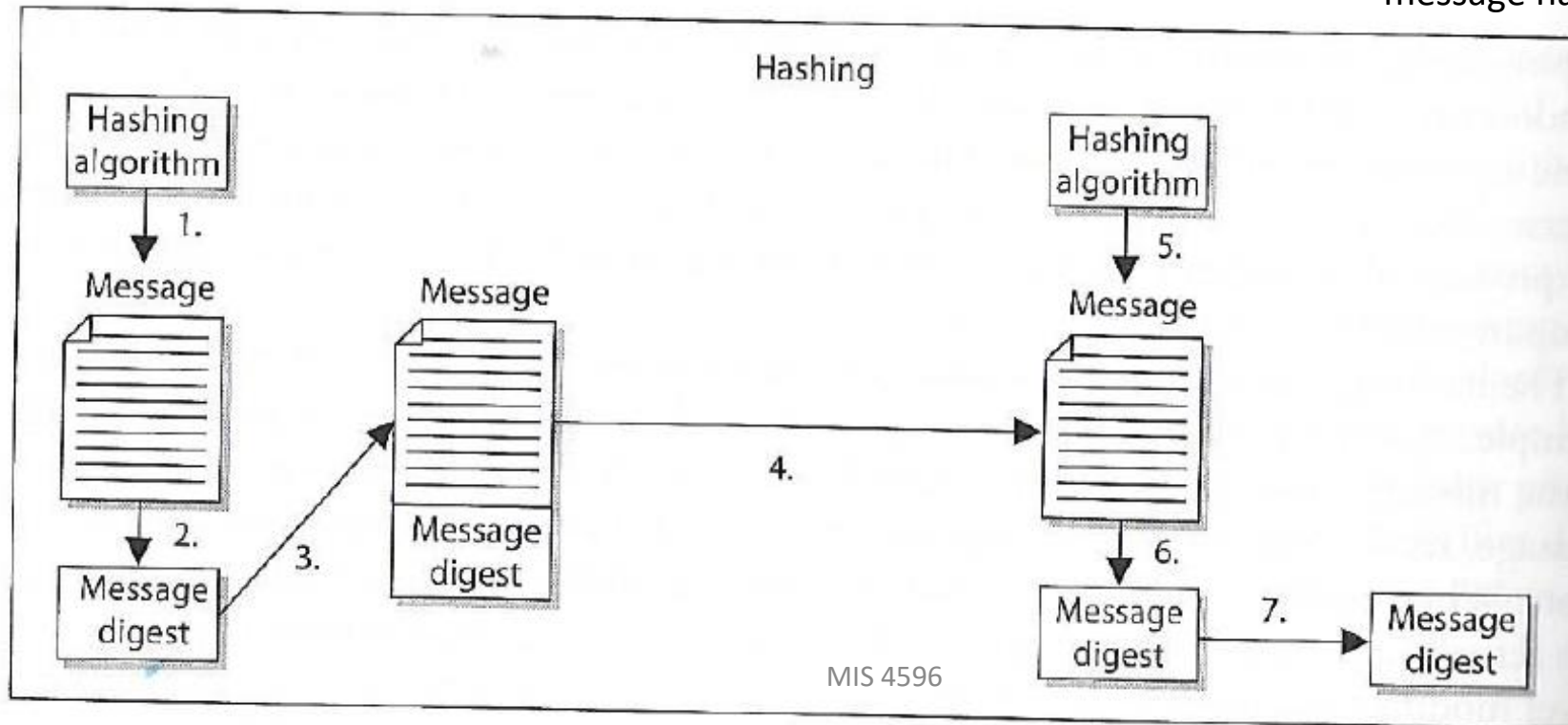

Note: Hashing results in **fixed-sized output**

- Names for the output of a hashing functions include “hash” and a *message digest (md)*, because a hash “digests” an input of any size down to a **fixed-sized output**
- No matter the size of the input, the out put is the same, for example the md5 hash function’s output:
 - Letter ‘a’ in binary: 01000001 => md5 hash => 32-character string
 - Blu-ray disk digest => md5 hash => 32-character string
 - 6 TB hard drive digest => md5 hash => 32-character string

One-way hash example...

Testing the integrity of a file (e.g. program) downloaded from the internet...

Secure | <https://www.kali.org/downloads/>

KALI
BY OFFENSIVE SECURITY

Blog Downloads Training Documentation Community About Us

Kali Linux Downloads

Download Kali Linux Images

We generate fresh Kali Linux image files every few months, which we make available for download. This page provides the links to **download Kali Linux** in its latest official release. For a release history, check our Kali Linux Releases page. Please note: You can find unofficial, untested weekly releases at <http://cdimage.kali.org/kali-weekly/>.

Image Name	Download	Size	Version	sha256sum
Kali 64 bit	HTTP Torrent	2.8G	2017.2	4556775bfb981ae64a3cb19aa0b73e8dcac6e4ba524f31c4bc14c9137b99725d
Kali 32 bit	HTTP Torrent	2.9G	2017.2	7f5000d8f55469264399a8bb7358fc22bec87fb1dc8a51b87f26876634e3effc
Kali 64 bit Light	HTTP Torrent	0.8G	2017.2	369a29defff40dff4f53fb47a6015d41d4ada8833a0b6e159657d2f223670f8b
Kali 32 bit Light	HTTP Torrent	0.8G	2017.2	f6ee21b2880501caee8aa47960e8f424dab5fae1a13ba4b4e02d45152b6acd0d
Kali 64 bit e17	HTTP Torrent	2.6G	2017.2	20dee81d9891aa6dcfe505a68692f98f981b43a14234d18d9edd92373d6ed6ab
Kali 64 bit Mate	HTTP Torrent	2.8G	2017.2	9c99a2cc52b1d48875681d12e1fcf6b0b003d44f7ceb610438b5bea148414810
Kali 64 bit Xfce	HTTP Torrent	2.7G	2017.2	9ecf6a054de1e3ad04d4063e3d347efb31326078c104ec2e78ab456fc4d2a578
Kali 64 bit LXDE	HTTP Torrent	2.7G	2017.2	c832df6b7a8e7074a5d7f5a50245b840a3df72ffdd4d19a5d1f647beebb4f299
Kali armhf	HTTP Torrent	0.6G	2017.2	a7f3e648ce9784589245c18d84e2273eb1f4ec1b78244a2c6d4465f3744c9198

MIS 4596

Follow us on Twitter

- Follow @kallinux 155K followers
- Follow @offsecraining 125K followers
- Follow @exploitdb 128K followers

f in v g r

Ready for the OSCP?

OFFENSIVE[®] security OSCP

Join the ever growing group of well trained and highly skilled **Offensive Security Certified Professionals**. Learn hands-on, real world **penetration testing** from the creators of Kali Linux.

One-way hash example...

Image Name	Download	Size	Version	sha256sum
Kali 64 bit	HTTP Torrent	2.8G	2017.2	4556775bfb981ae64a3cb19aa0b73e8dcac6e4ba524f31c4bc14c9137b99725d

```
Windows PowerShell
PS C:\Users\tue87168> cd Downloads
PS C:\Users\tue87168\Downloads> dir *.iso

Directory: C:\Users\tue87168\Downloads

Mode                LastWriteTime         Length Name
----                -
-a----             8/10/2017 10:55 AM         674803712 CSET_8.0 (1).iso
-a----             8/10/2017 11:03 AM         674803712 CSET_8.0 (2).iso
-a----             6/12/2017 10:29 AM         674803712 CSET_8.0.iso
-a----             9/27/2017  3:03 PM         2421987328 en_project_professional_2016_x86_x64_dvd_6962236.iso
-a----             10/3/2017  8:49 PM         2421987328 en_visio_professional_2016_x86_x64_dvd_6962139.iso
-a----            11/11/2016 11:45 AM         1469054976 Fedora-Live-Workstation-x86_64-23-10.iso
-a----            11/9/2017  2:31 PM         3020619776 kali-linux-2017.2-amd64.iso

PS C:\Users\tue87168\Downloads> Get-FileHash kali-linux-2017.2-amd64.iso | Format-List

Algorithm : SHA256
Hash      : 4556775BFB981AE64A3CB19AA0B73E8DCAC6E4BA524F31C4BC14C9137B99725D
Path      : C:\Users\tue87168\Downloads\kali-linux-2017.2-amd64.iso

PS C:\Users\tue87168\Downloads> _
```

One-way hash example...

```
Windows PowerShell
PS C:\Users\tue87168\Downloads> dir *.txt

Directory: C:\Users\tue87168\Downloads

Mode                LastWriteTime         Length Name
----                -
-a----            11/9/2017   3:04 PM           15 MIS5206-IsGood.txt

PS C:\Users\tue87168\Downloads> type MIS5206-IsGood.txt
MIS5206 is good
PS C:\Users\tue87168\Downloads> Get-FileHash MIS5206-IsGood.txt | Format-List

Algorithm : SHA256
Hash      : E6F053ADE3857C0EDC2896B229D0B91D4752B2D9D8C9BD4B2A45A4ACCB3999DD
Path      : C:\Users\tue87168\Downloads\MIS5206-IsGood.txt

PS C:\Users\tue87168\Downloads> type MIS5206-IsGood.txt
MIS5206 is goop
PS C:\Users\tue87168\Downloads> Get-FileHash MIS5206-IsGood.txt | Format-List

Algorithm : SHA256
Hash      : 877B45EA5D40D98FF8D1ABD919E154F446FEA11387DBB13DDEE448F9932928A5
Path      : C:\Users\tue87168\Downloads\MIS5206-IsGood.txt

PS C:\Users\tue87168\Downloads>
```

Notice the amount of confusion and diffusion resulting from a 1 character change!

Q: You own a website and let users create accounts. How do you store their passwords in your database?

```
syslog:*:17345:0:99999:7:::
_apt:*:17345:0:99999:7:::
messagebus:*:17345:0:99999:7:::
uidd:*:17345:0:99999:7:::
lightdm:*:17345:0:99999:7:::
ntp:*:17345:0:99999:7:::
avahi-autoipd:*:17345:0:99999:7:::
avahi:*:17345:0:99999:7:::
dnsmasq:*:17345:0:99999:7:::
colord:*:17345:0:99999:7:::
speech-dispatcher:!:17345:0:99999:7:::
hplip:*:17345:0:99999:7:::
kernoops:*:17345:0:99999:7:::
pulse:*:17345:0:99999:7:::
nm-openvpn:*:17345:0:99999:7:::
rtkit:*:17345:0:99999:7:::
saned:*:17345:0:99999:7:::
usbmux:*:17345:0:99999:7:::
deargle:$6$ire.kWgu$XpWcXUpP4ok47yr.nXKXcRbpy1yaw.04Ez94.aDQbRJMr8Zsu2H57xswYI
sshd:*:17360:0:99999:7:::
postgres:*:17369:0:99999:7:::
vboxadd:!:17384:::~:~:~:~:
```

`/etc/shadow` file from a linux computer, where username passwords are stored.

Password is hashed!
Don't store plaintext passwords.

Cryptanalysis Attack

- Collisions
 - *Two different messages with the same hash value*
 - Based on the “birthday paradox”
 - Hash algorithms should be resistant to this attack

The birthday paradox, also known as the birthday problem, states that in a random group of 23 people, there is about a 50 percent chance that two people have the same birthday.

Is the Birthday Attack Real?

- There are multiple reasons why this seems like a paradox
- One is that when in a room with 22 other people, if a person compares his or her birthday with the birthdays of the other people it would make for only 22 comparisons—only 22 chances for people to share the same birthday.

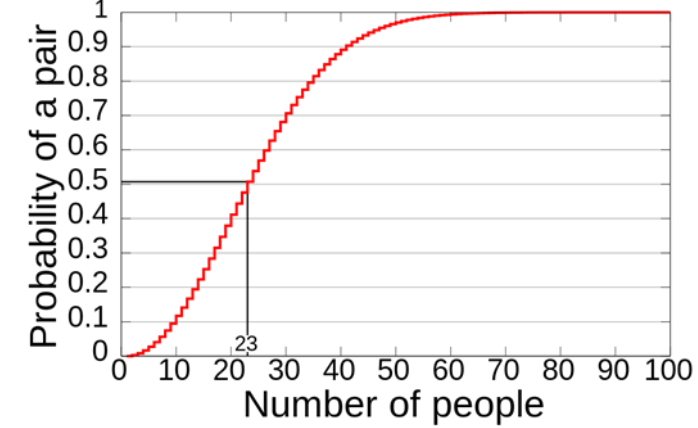

When all 23 birthdays are compared against each other, it makes for much more than 22 comparisons. How much more? Well, the first person has 22 comparisons to make, but the second person was already compared to the first person, so there are only 21 comparisons to make. The third person then has 20 comparisons, the fourth person has 19 and so on. If you add up all possible comparisons ($22 + 21 + 20 + 19 + \dots + 1$) the sum is 253 comparisons, or combinations. Consequently, each group of 23 people involves 253 comparisons, or 253 chances for matching birthdays.

MD5 (Message Digest 5)

- A 128-bit hash algorithm, still in common use
- Has been broken
- 128-bit hash, but only need $2^{128/2} = 2^{64}$ to find a collision
- Not strong enough for modern computers

SHA -1 (Security Hash Algorithm 1)

- A 160-bit hash algorithm, still in common use
- Has been broken
- 160-bit hash, but only need $2^{160/2} = 2^{80}$ to find a collision
- No longer strong enough for modern computers

MD5 Hash collision attack example...

1. Open a PowerShell terminal
2. Run `get-filehash program*.exe -Algorithm MD5`
3. Switch to USB drive, Switch to folder...
4. `.\ProgramA`
5. `.\ProgramB`

The malware Flame used a MD5 hash collision to hijack Microsoft Windows Update and spread itself across networks

- Flame collected **audio, keystrokes, screenshots** which it sent to a malicious server
- Found a collision within a single millisecond
- Cost ~\$200k computing time just for 1ms
- Attributed to advanced persistent threat group [Equation Group](#)
- Espionage attacks on countries in and around Iran

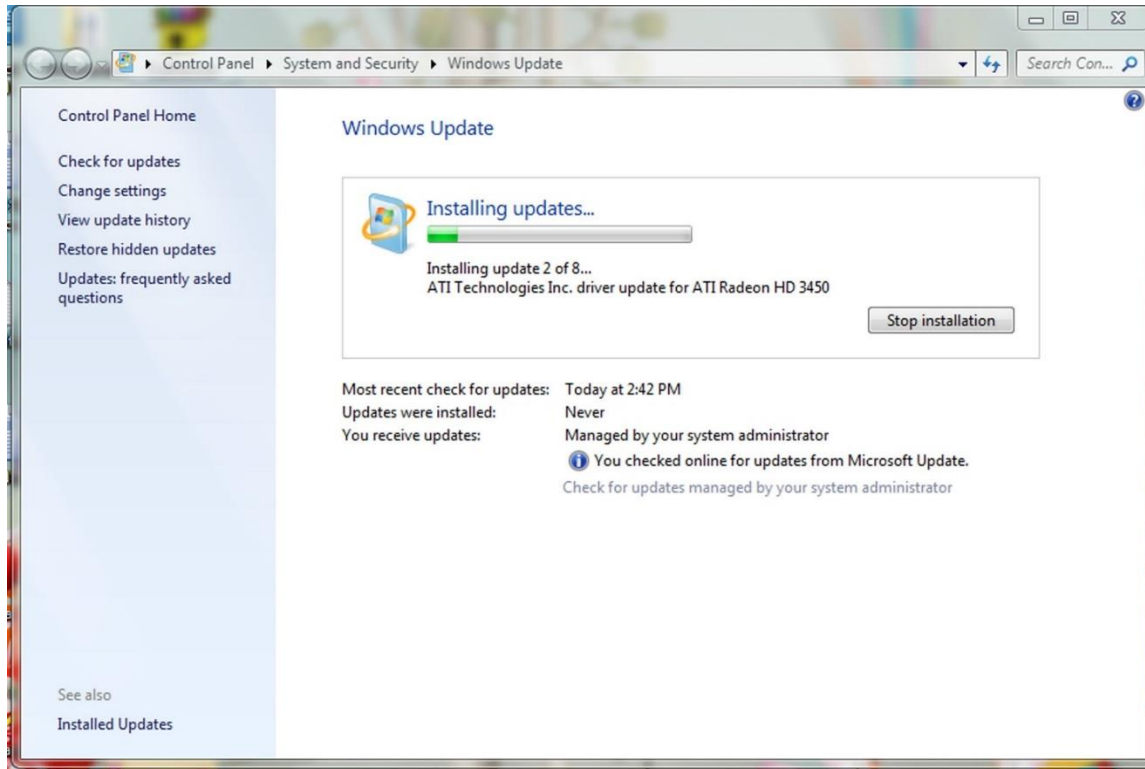

Hashing algorithms are used for browser ssl (secure sockets layer)

- In 2014, many sites were still using SHA-1, at the time known to be dangerously vulnerable
- Google declared state of emergency to push companies to upgrade

Why Google is Hurrying the Web to Kill SHA-1

published by [Eric Mill](#) on September 7, 2014, [58 comments](#)

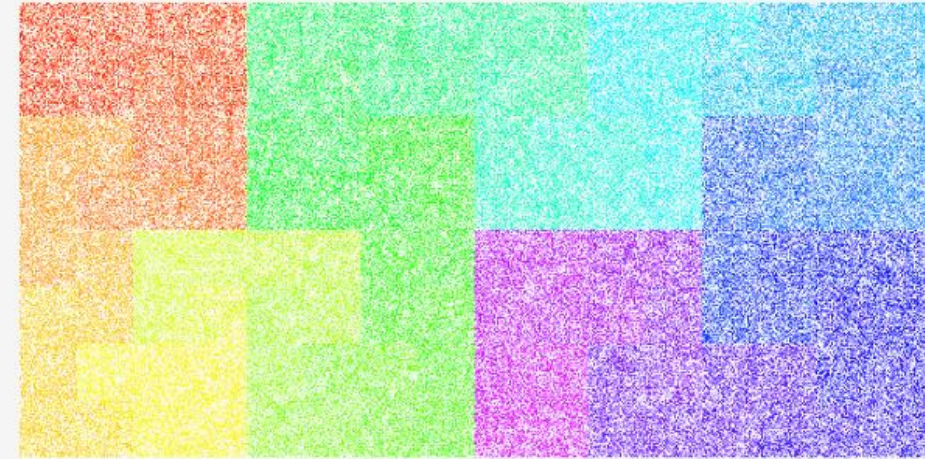

Hilbert map of hashing algorithms, by [Ian Boyd](#)

Most of the secure web is using an insecure algorithm, and Google's just declared it to be a slow-motion emergency.

Something like [90% of websites](#) that use SSL encryption — [https://](#) — use an algorithm called [SHA-1](#) to protect themselves from being impersonated. This guarantees that when you go to [https://www.facebook.com](#), you're visiting the real Facebook and not giving your password to an attacker.

Unfortunately, [SHA-1 is dangerously weak](#), and has been for a [long time](#). It gets weaker every year, but remains widely used on the internet. Its replacement, [SHA-2](#), is strong and supported [just about everywhere](#).

Google [recently announced](#) that if you use Chrome, then you're about to start seeing a progression of warnings for many secure websites:



What's [about to befall websites](#) with SHA-1 certificates that expire in 2017, in Chrome.

The first set of warnings will hit before Christmas, and will keep getting more stern over the

SHA-2 uses 224, **256**, 384, and 512-bit hashes

- But... it is built using the design of SHA-1, and prone to the same weaknesses
- It's believed to be a matter of time before SHA-2 is also exploited

• SHA-3 was just ratified recently by NIST, the U.S. National Institute of Standards and Technology

- It was the result of a six-year hashing competition. Also uses 224-, 256-, 384-, 512-bit hashes

Why does this matter for businesses?

Business needs a reliable way to prove integrity of data, files, programs, that can be trusted

Digital Signature

- A hash value encrypted with the sender's private key
- The act of signing means encrypting the message's hash value with the private key

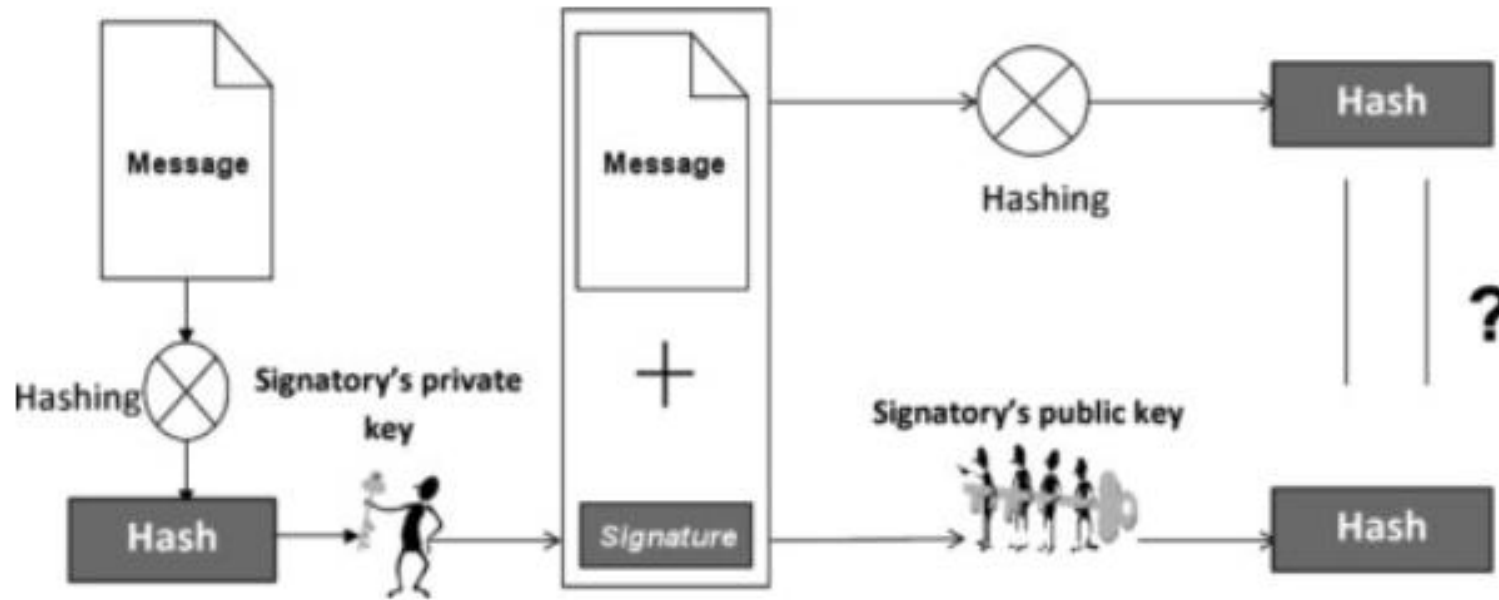

Services of cryptosystems

- ✓ **Confidentiality** – Renders information unintelligible except by authorized entities
- ✓ **Authentication** – Verifies the identity of the user or system that created, requested or provided the information
- ✓ **Nonrepudiation** – Ensure the sender cannot deny sending the information
- ✓ **Integrity** – Data has not been altered in an unauthorized manner since it was created, transmitted, or stored

Summary of some characteristics of cryptographic algorithms

Feature / Algorithm	Hash	Symmetric	Asymmetric
No. of Keys	0	1	2
NIST recommended Key length	256 bits	128 bits	2048 bits
Commonly used	SHA	AES	RSA
Key Management/Sharing	N/A	Big issue	Easy & Secure
Effect of Key compromise	N/A	Loss of both sender & receiver	Only loss for owner of Asymmetric key
Speed	Fast	Fast	Relatively slow
Complexity	Medium	Medium	High
Examples	SHA-224, SHA-256, SHA-384 or SHA-512	AES, Blowfish, Serpent, Twofish, 3DES, and RC4	RSA, DSA, ECC, Diffie-Hellman