

## Fly-By-Night Case

You are working on a big project as a Business Analyst at Fly-By-Night (FBN) Trucking. You are focusing on FBN's inventory management problem, but you have been asked to review the work of the team's most junior member who is assigned to the truck loading and bill of lading sub-process. You remember that the Bill of Lading is the list of orders that are loaded onto a truck for delivery. While you have not examined this process yourself, you have worked around it for several years and you have a general understanding,

### You know that:

•**Shipments are planned by the shipping clerk.** The Customer Service Representative prints a copy of the customer's order from the Order Tracking System (OTS) for both the forklift driver and the shipping clerk. The clerk separates the orders into two batches, one for local delivery and one for out-of-town delivery. You think he uses zip codes to make this decision. Zip codes of 19220, 19221, and 19222 refer to local deliveries that will be made by a FBN truck. At the warehouse, forklift drivers pick the goods item by item until he has picked every item and the order is complete. Once complete, he brings the orders to the loading dock. If he can't find something and the order is short one or more items, he takes the rest of the items to a temporary storage location and passes his copy of the order to the warehouse foreman. The foreman then investigates why the item(s) is missing. If he can fix the problem within 24 hours he does so. If it looks like a bigger problem, he sends the order back to the CSR and asks him to contact the customer and ask how they want to proceed.

Assuming the completed orders get to the loading dock, the shipping clerk matches them to his copies. He then types that order onto the appropriate bill of lading for the truck driver including customer name, ship-to address, number of items and their combined weight. When the bill of lading fills up to its maximum carrying weight, the shipping clerk orders a truck in the case of out-of-town deliveries. He knows the company truck makes a run each day, so he just keeps adding orders to its bill of lading for that day. When either truck arrives, the shipping clerk gives the bill of lading to the driver who checks as Fly-By-Night's forklift drivers load each order onto the truck. Once the driver is sure that all orders have been loaded, he signs the bill of lading, gives a copy back to the shipping clerk, and leaves. The shipping clerk must enter the shipment data into the system to close out the order by the time his shift is over.

### Your Assignment

You are now looking at the swim lane diagram that the new Business Analyst has produced. *Read them carefully, analyze them and try to understand what matches with your understanding and what doesn't. There are some things missing, some done incorrectly and some questions that should be asked. What are they?*

Once you think you understand the process and where the novice business analyst has made mistakes, go on to answer the questions.

## FBN Shipping Process

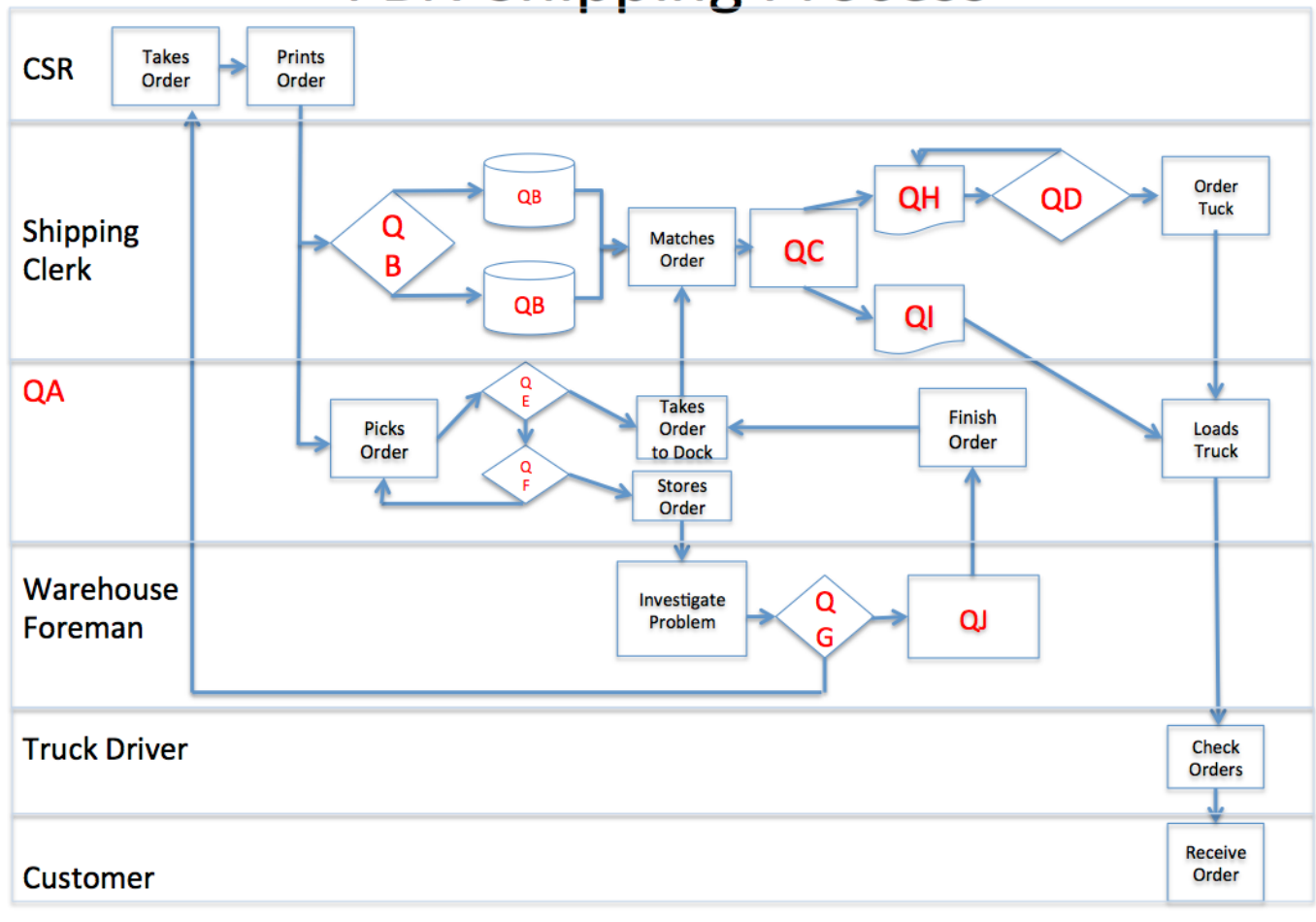

1. What is the role of the stakeholder represented by QA in the swim lane diagram?
  - a. Warehouse Manager
  - b. Forklift Driver
  - c. Warehouse Quality Analyst
  - d. Data Entry Clerk
  
2. What decision is represented by the diamond QB?
  - a. In inventory/yes, no?
  - b. Rush shipment/yes, no?
  - c. Where going/local, remote?
  - d. Quality/good, bad?
  
3. What activity is the shipping clerk doing in the rectangle labeled QC?
  - a. Rechecking match of goods to order
  - b. Entering match into database
  - c. Placing order on a Bill of Lading
  - d. Checking if local or remote shipment
  
4. What decision is the shipping clerk making in the diamond QD?
  - a. Will this fill the truck?
  - b. Is this a local or remote shipment?
  - c. Have we shipped to this customer before?
  - d. What trucking company will I use?
  
5. You have the feeling that someone or something (a lane) is missing from the swim lane diagram. What would you tell the new BA to add?
  - a. The customer placing the order
  - b. The database used to track shipments
  - c. The salesperson responsible for the customer
  - d. The inventory clerk in the warehouse
  
6. You want to simplify the chart, which lane would you eliminate?
  - a. The customer
  - b. The CSR
  - c. The truck driver
  - d. No one, you need them all in the truck loading process
  
7. It occurs to you that the new BA has missed a KEY step or two in this process? Are they:
  - a. Signing the Bill of Lading and recording the shipment
  - b. Getting a truck order confirmation and matching it when the truck arrives
  - c. Calling the CSR to verify that the ship-to address is still accurate
  - d. Collecting payment for the order from the customer.