

Firewalls, IDS and IPS

- Unit #6 -

MIS5214

Agenda

- Introduction
 - Physical “air-gap” security and how we undermined it
- Firewalls
 - Types of firewalls
 - Some architectural patterns based on firewall placement
 - Firewalls have rules
- Intrusion Detection System (IDS) & Intrusion Prevention System (IPS)
- Defense in Depth with security zones (“Security Domains”)
- Project Team Assignment
- Preparation for Mid Term Exam

What is implied by this model of security?

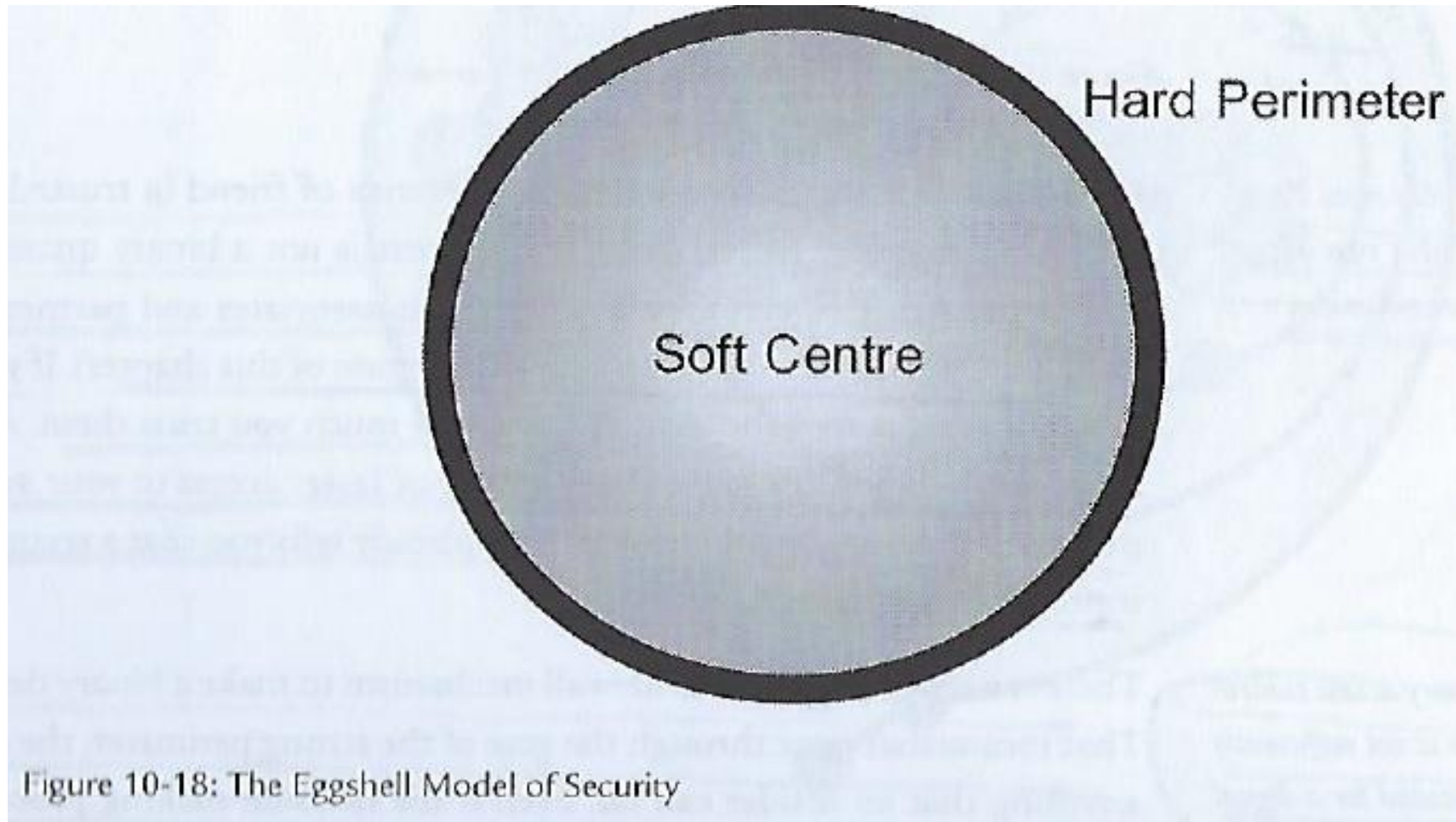

What is implied with this architectural model?

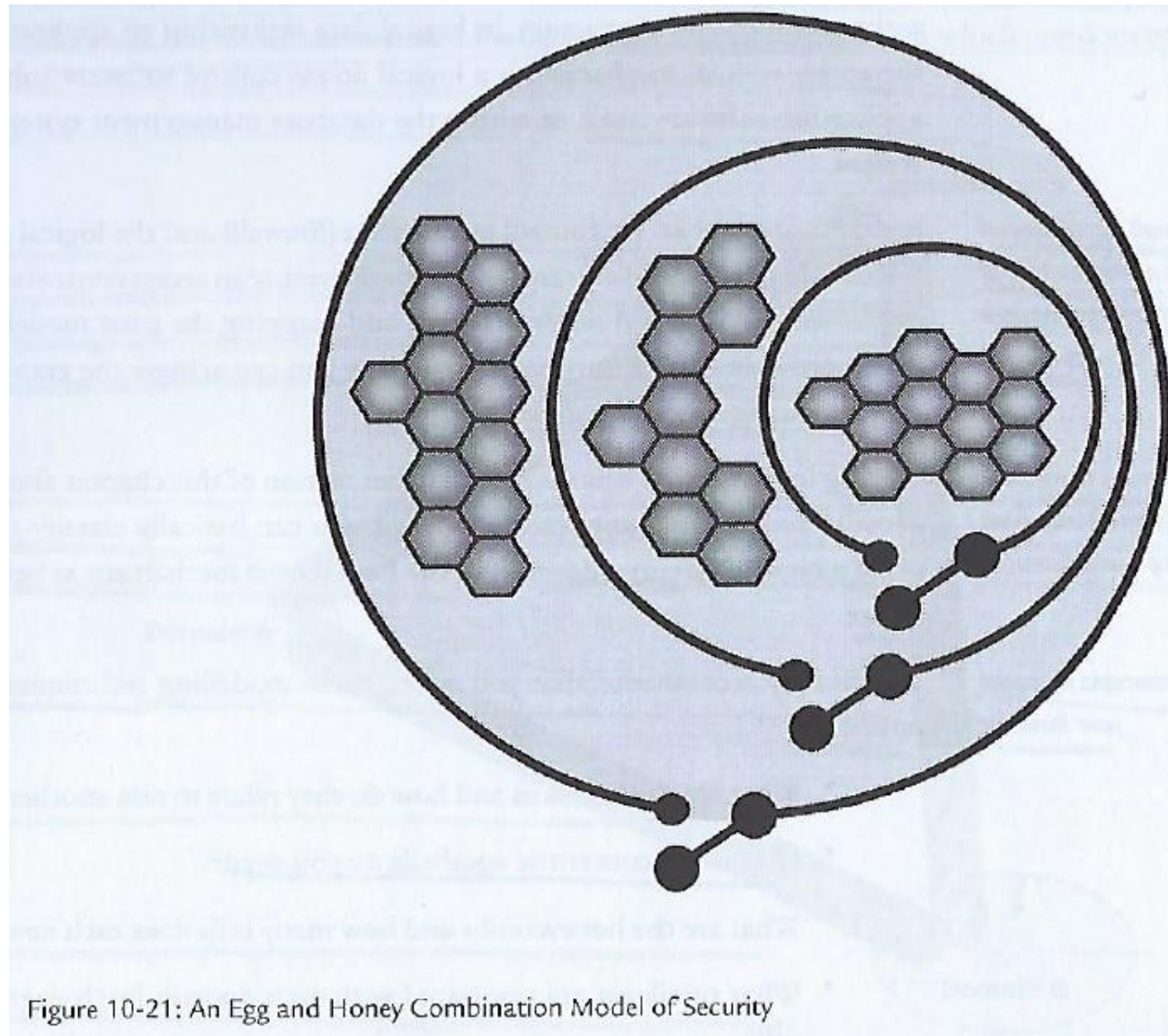

Figure 10-21: An Egg and Honey Combination Model of Security

Early computer architecture of automated control systems separated Corporate and Control Domains

Critical infrastructure systems supporting major industries are dependent on information systems for command and control

- Financial, Manufacturing, Transportation, Energy, Water...

Highly dependent on disparate legacy proprietary control systems which were physically isolated from corporate information systems

- *Control system security used to mean physical security of a closed-loop system*



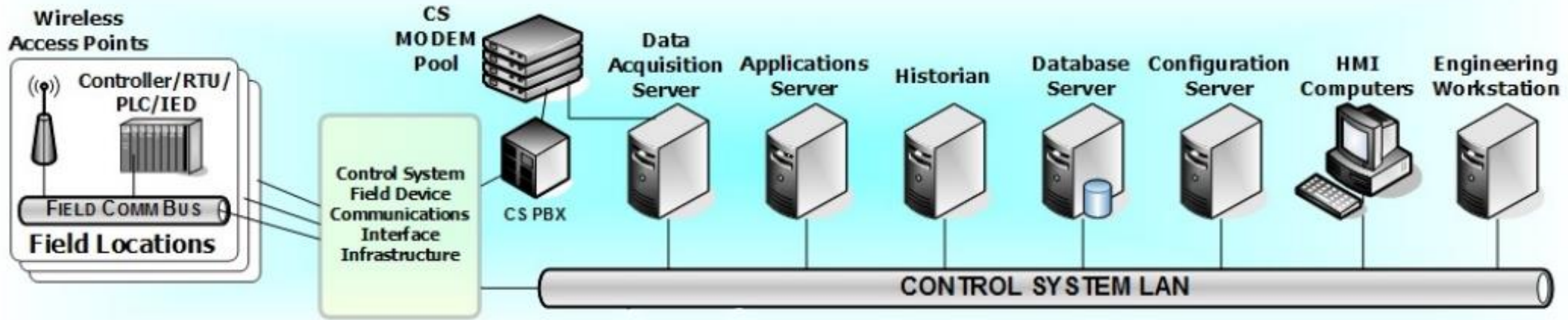

- LAN 1 – connected via
- layer 2 switch
 - PBX

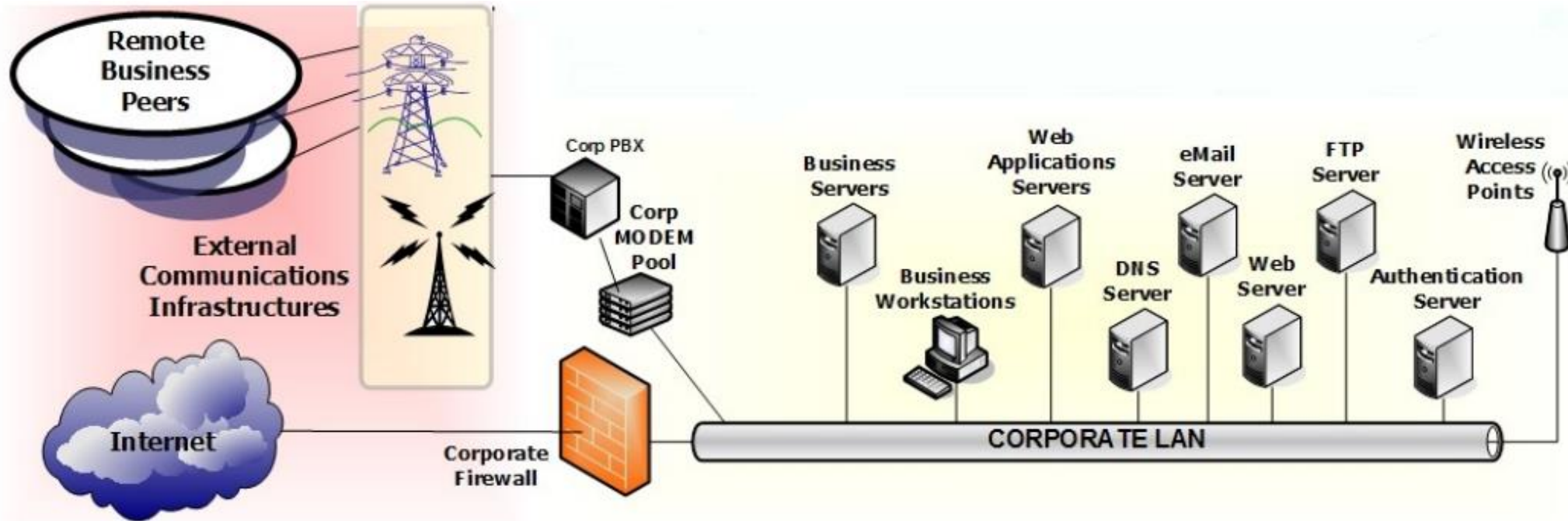

- LAN 2 – connected via
- layer 2 switch
 - PBX

HMI = Human Machine Interface

CS = Control System

PBX = Private Branch Exchange telephone system switches between users on local lines while allowing users to use a fixed # of external phone lines

RTU = Remote Terminal Unit is a computer controlled device that connects physical machines to distributed control systems

PLC = Programmable Logic Controller

IED = Intelligent End device

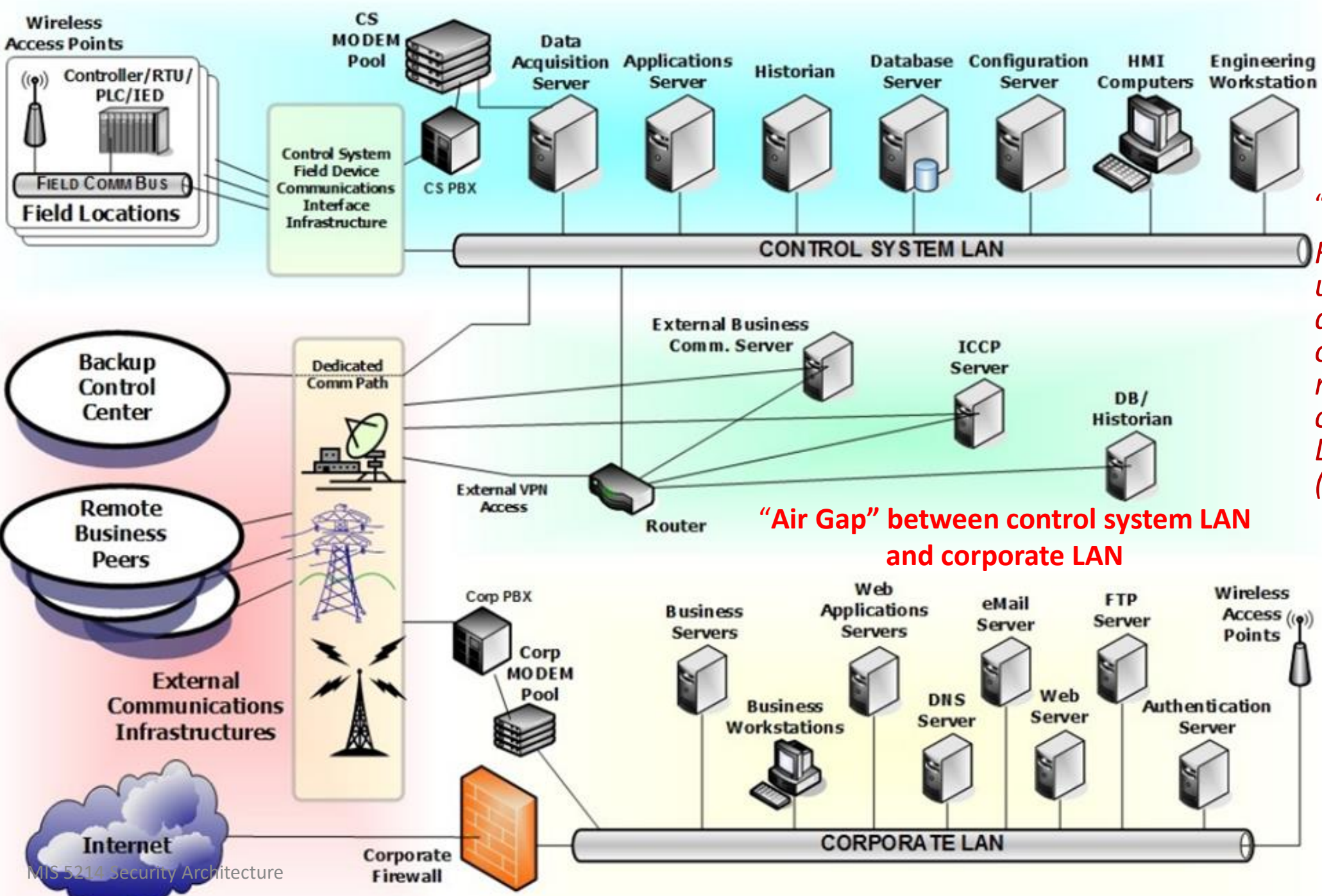

Security based on Isolation from the Internet

“Security by Obscurity”

Few, if any, understood the architecture or operation of the resources on the controls systems Local Area Network (LAN)

“Air Gap” between control system LAN and corporate LAN

Worked well for environments that had no external connections

Allows organization to focus on physical security

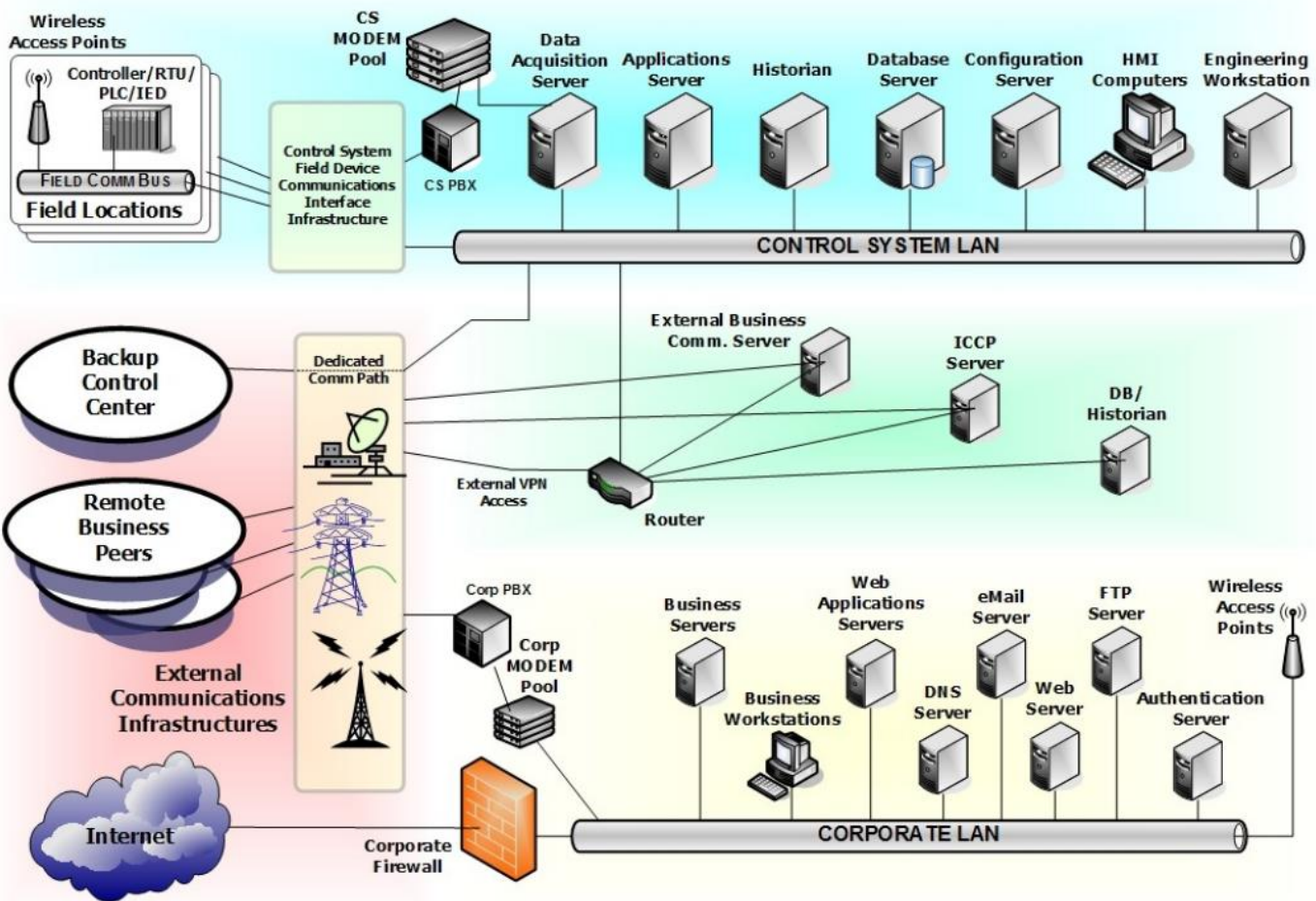

Traditional isolation of corporate and control domains

Total isolation from the untrusted external network resulted in reduced need for communications security

- Only threats to operations were physical access to a facility or plant floor
- Most data communication in isolated information infrastructure required limited authorization and security oversight
- Operational commands, instructions and data acquisition occurred in a closed environment where all communications were trusted

If a command or instruction was sent via the network it was expected to arrive and perform the authorized function – as only authorized operators had access to the system

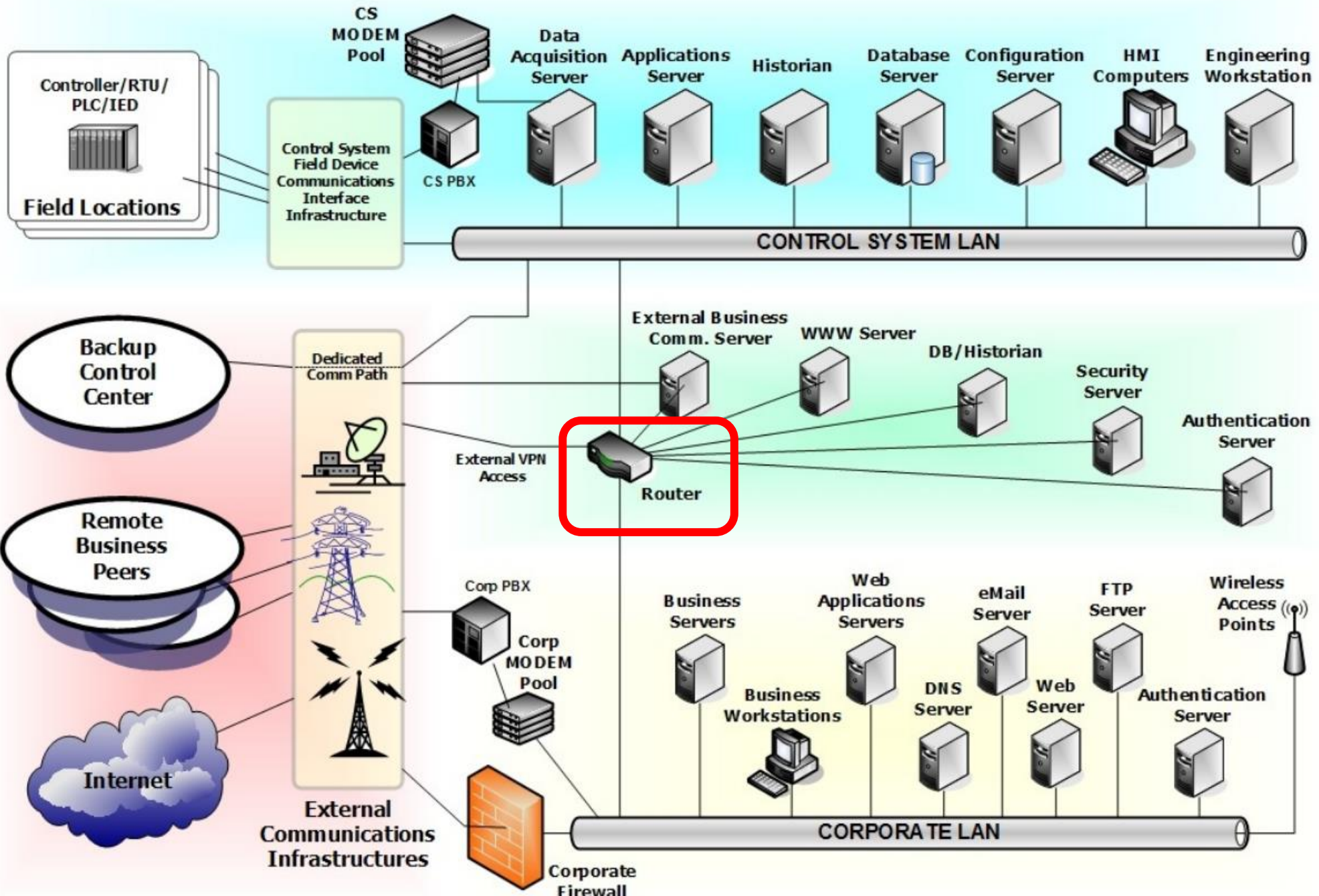

Year ~2000 saw isolated control system networks beginning to be interconnected with corporate networks via simple routers

Router is a networking device that forwards data packets between computer networks

Routers perform the traffic directing functions on the Internet

Many previously isolated industrial control system networks were interconnected as part “IT modernization”

Introducing IT components into the control system domain continues to result in security problems:

- No business case for cyber security in control system environments
- Increased dependency on automation of control systems
- Use of technologies we now know have vulnerabilities
- Considerable amount of open source information available on control system configurations and operations
- Legacy control system communication protocols lack security functionality
- Control system technologies have limited security, and if they do – vendor supplied security capabilities often enabled if the administrator is aware of the capability

Attack begins at some point outside the control zone, after initial intrusion attacker pries deeper and deeper into the architecture

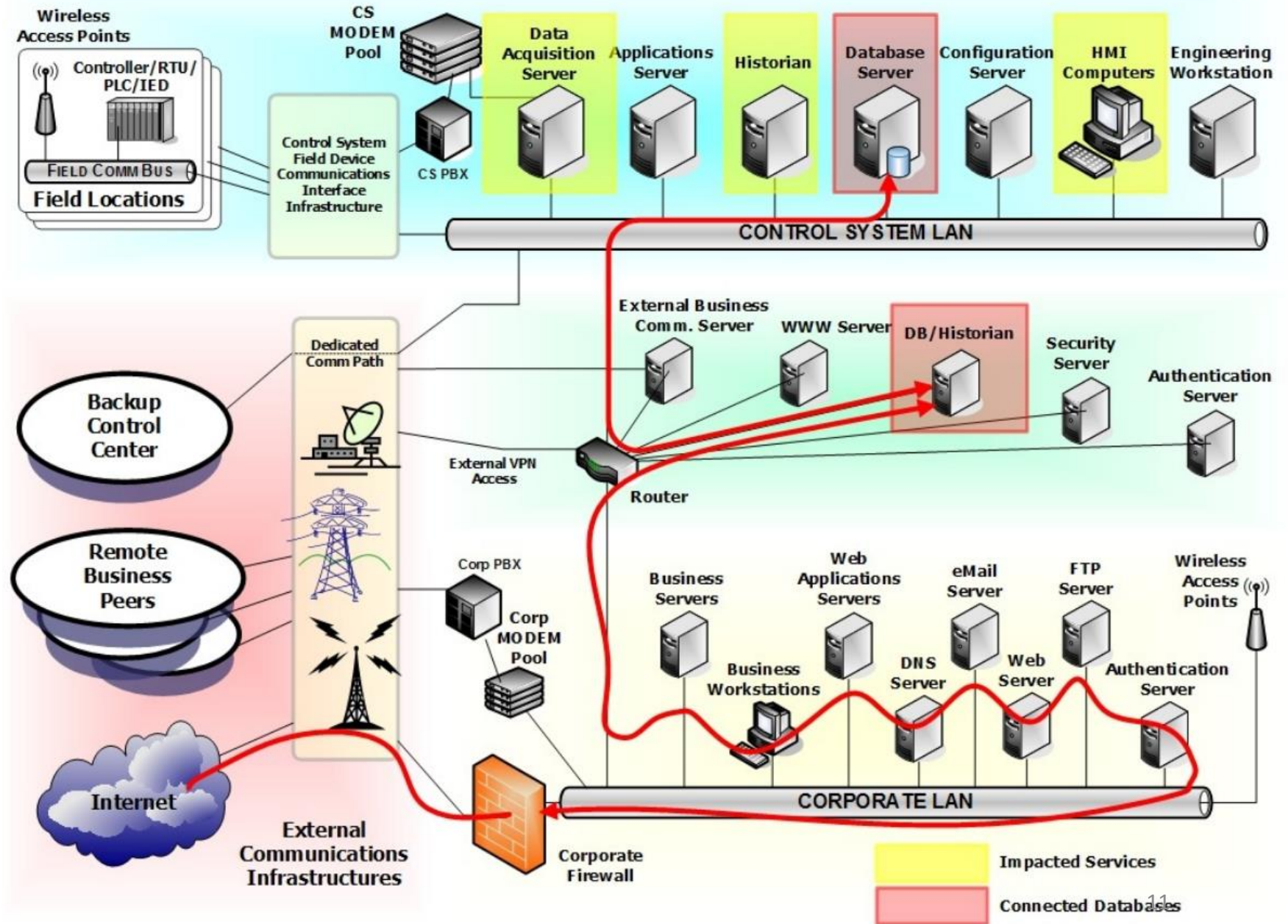

Risk of Multilayer protocols –

Distributed Network Protocol 3 (DNP3) communications protocol for SCADA systems used by water and power utilities

Not all protocols fit nicely within OSI model layers, especially in the case of devices on networks that were never intended to interoperate with the Internet

- DNP3 lacked robust security features for protecting CIA of data it was used to communicate
- Previously isolated devices and networks increasingly connected to unanticipated threats

DNP3 created before networking with OSI's 7 layer model was a consideration

- DNP3's developers used Enhanced Performance Architecture (EPA) that approximated OSI layers: 7 (app), 4 (transport) & 2 (data link)
 - No presentation layer (layer 6) encryption or authentication
 - No session management (layer 5)
- No Intrusion Detection Systems able to understand connections between DNP3 and IP networks and identify DNP3 attacks!

December 2015 – attackers cut power to utilities' supervisory control and data acquisition (SCADA) systems creating first known cyberattack created blackout impacting 80,000 homes in Ukraine

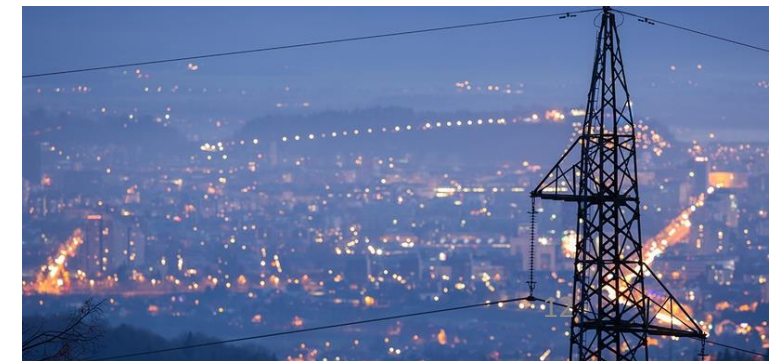
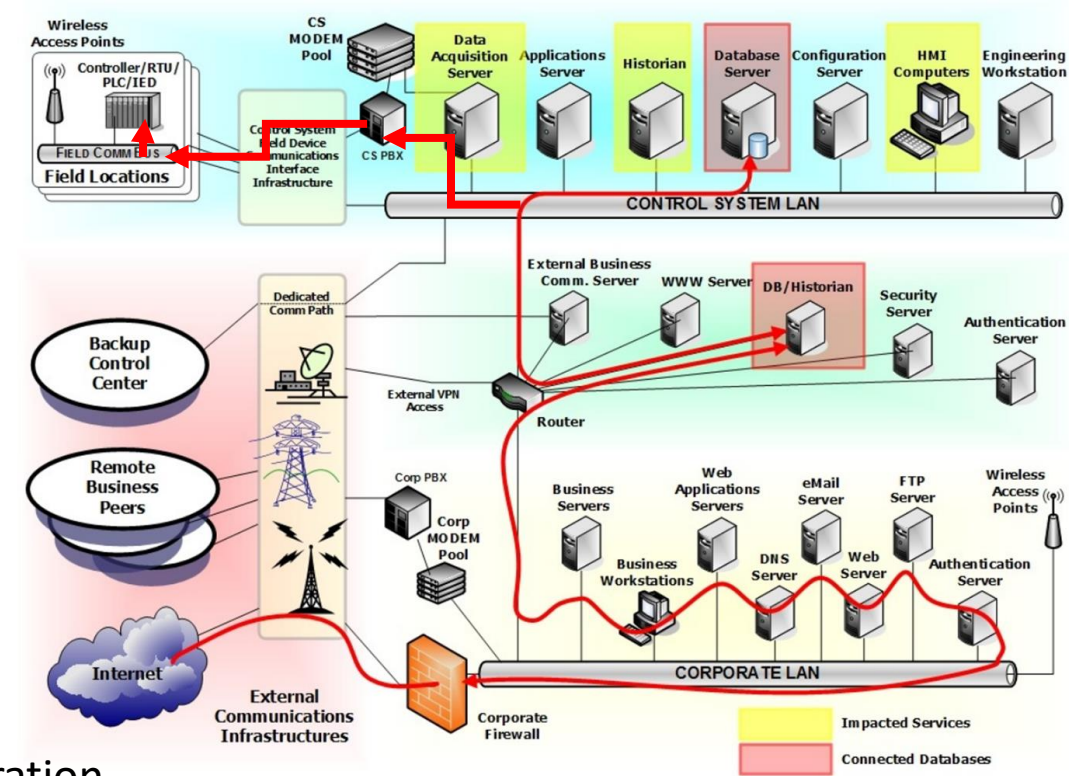

Agenda

- ✓ Introduction

 - ✓ Physical “air-gap” security and how we undermined it

- Firewalls

 - Types of firewalls
 - Some architectural patterns based on firewall placement
 - Firewalls have rules

- Intrusion Detection System (IDS) & Intrusion Prevention System (IPS)

- Defense in Depth with security zones (“Security Domains”)

- Project Team Assignment

- Preparation for Mid Term Exam

Defense in Depth is achieved through Network Segmentation to create Security Domains

- IT network infrastructure domains are sets of logical (and physical) resources available to a subject
 - User
 - Process
 - Application
- Resources within each domain are:
 - Working under the same security policy
 - Managed by the same group
- Different domains are separated by logical boundaries created by components that enforce security policy for each domain, such as:
 - Firewalls
 - Directory services making access decisions
 - Objects having their own access controls indicating which individuals and groups can access and run operations/processes on them

Firewalls used to Implement Network Security Policy

- Support and enforce an organization's network security policy
- Implement high-level directives on acceptable and unacceptable actions to protect critical assets
- Firewall security policy:
 - What services can be accessed
 - What IP addresses and ranges are restricted
 - What ports can be accessed

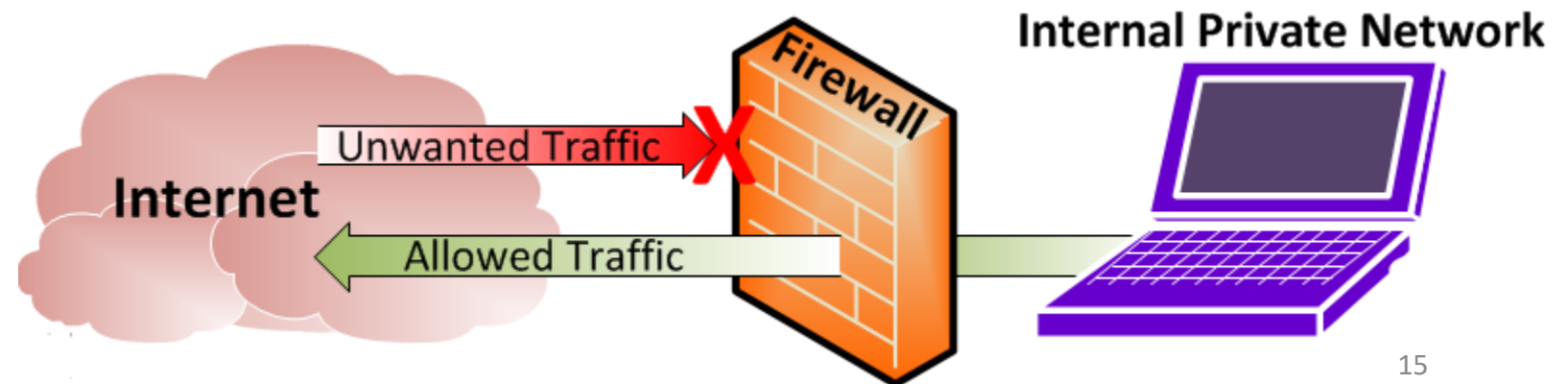

Firewalls are security architecture “choke points” in an IT network

- All communication should flow through, be inspected and restricted by firewalls
- Firewalls are used to restrict access from one network to another network
 - From the internet to access corporate networks
 - Between internal network segments
- Restrict access
 - Between origin and destination
 - Based on determination of acceptable traffic type(s)



Firewall Technology

- May be implemented as a
 - Software product running on a server
 - Specialized hardware appliance
- Monitors data packets coming into and out of the network it is protecting
- Packets are filtered by:
 - Source and destination addresses and ports
 - Header information
 - Protocol type
 - Packet type
 - Service
 - Data content – i.e. application and file data content

Types of Firewalls

1. Packet filtering
2. Dynamic packet filtering
3. Stateful inspection
4. Proxy Firewall
5. Kernel Proxy

Packet-filtering firewalls

“First-generation” firewall technology – most basic and primitive

Capabilities built into most firewalls and routers

- Configured with access control lists (ACLs) which dictate the type of traffic permitted into and out of the network
- Filters compare protocol header information from network and transport layers with ACLs

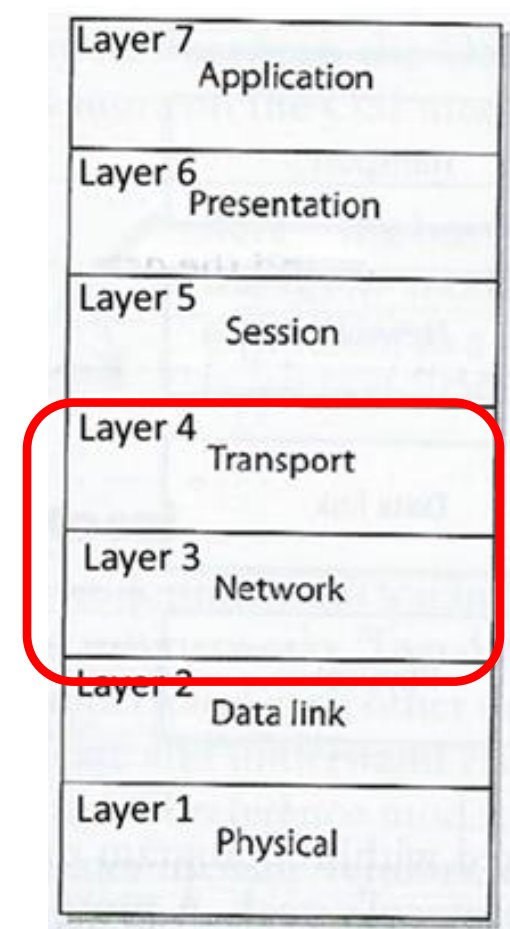

Packet-filtering Firewalls

Compares ACLS with network protocol header values to determine permit/deny network access based on:

1. Source and destination IP addresses
2. Source and destination port numbers
3. Protocol types
4. Inbound and outbound traffic direction

Network Layer 3

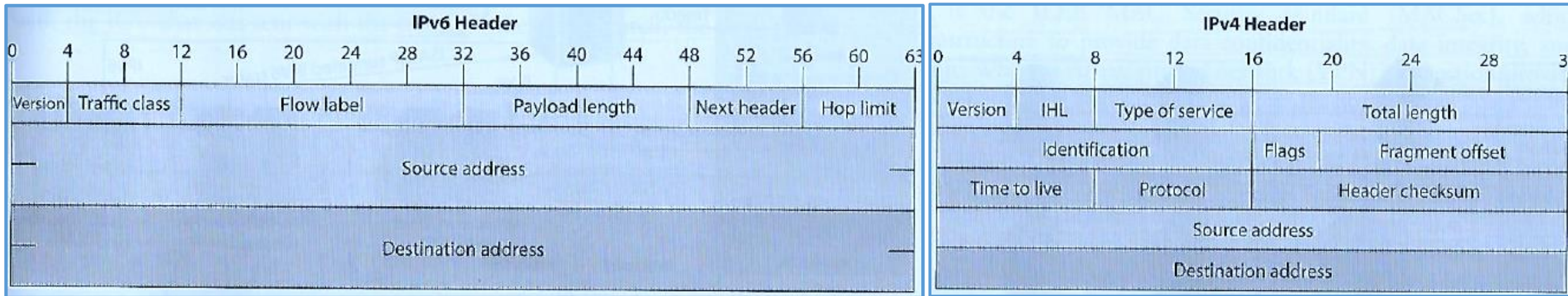

TCP format

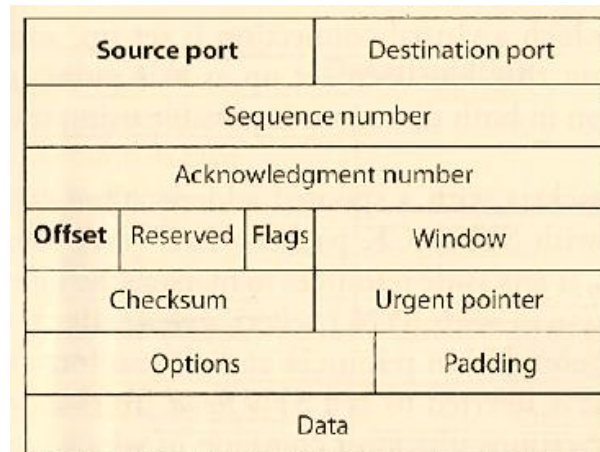

UDP format

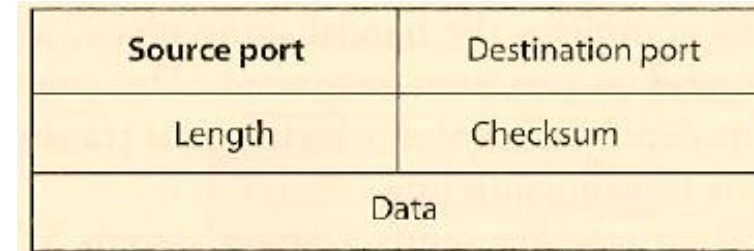

Transport Layer 4

TCP/IP Port numbers

Ports 0 to 1023 are Well-Known Ports

Ports 1024 to 49151 are Registered Ports – Often registered by a software developer to designate a particular port for their application

Ports 49152 to 65535 are Public Ports

Port #	Protocol	Description	Status
0	TCP, UDP	Reserved; do not use (but is a permissible source port value if the sending process does not expect messages in response)	Official
1	TCP, UDP	TCPMUX	Official
5	TCP, UDP	R...	
7	TCP, UDP	E...	
9	TCP, UDP	DI...	
11	TCP, UDP	S)	
13	TCP, UDP	D)	
17	TCP, UDP	Q)	
18	TCP, UDP	M)	
19	TCP, UDP	C)	
20	TCP	F)	
21	TCP	F)	
22	TCP, UDP	S)	
23	TCP, UDP	T)	
25	TCP, UDP	S)	
26	TCP, UDP	R)	
35	TCP, UDP	Q)	
37	TCP, UDP	T)	
38	TCP, UDP	R)	
39	TCP, UDP	R)	
41	TCP, UDP	G)	
42	TCP, UDP	H)	
43	TCP	W)	
49	TCP, UDP	T)	
53	TCP, UDP	D)	
57	TCP	M)	
67	UDP	B)	
68	UDP	B)	
69	UDP	T)	
70	TCP	G)	
79	TCP	F)	
80	TCP	H)	
81	TCP	T)	
82	UDP	T)	
88	TCP	K)	

Port # / Layer	Name	Description	Status
1080	socks	SOCKS network application proxy services	Official
1236	bvcontrol [rmtcfg]	Remote configuration server for Gracilis Packeten network switches [a]	Unofficial
1300	h323hostcallsc	H.323 telecommunication Host Call Secure	Official
1433	ms-sql-s	Microsoft SQL Server	Official
1434	ms-sql-m	Microsoft SQL Monitor	Official
1494	ica	Citrix ICA Client	Official
1512	wins	Microsoft Windows Internet Name Server	Official
1524	ingreslock	Ingres Database Management System (DBMS) lock services	Official
1525	prospero-np	Prospero non-privileged	Unofficial
1645	datametrics [old-radius]	Datametrics / old radius entry	Unofficial
1646	sa-msg-port [oldradacct]	sa-msg-port / old radacct entry	Official
1649	kermit	Kermit file transfer and management service	Official

Example ACL Rules

- Router configuration allowing TCP traffic to travel from system 10.1.1.2 to system 172.16.1.1 to SMTP (Simple Mail Transfer Protocol) port (port 25) :

permit tcp host 10.1.1.2 host 172.16.1.1 eq smtp

- Allow UDP traffic from 10.1.2 to 172.16.1.1:

permit udp host 10.1.1.2 host 172.16.1.1

- Block all ICMP (Internet Control Message Protocol) i.e. router error messages and operational information traffic from entering through a certain interface:

deny icmp any any

- Allow standard web traffic (to a web server listening on port 80) from system 1.1.1.1 to system 5.5.5.5:

permit tcp host 1.1.1.1 host 5.5.5.5 eq www

Packet-filtering firewalls

Packet filtering firewalls: monitor traffic and provide “stateless inspection” of header attribute values (i.e. delivery information) of individual packets

...and after the decision to permit or deny access to the network is made the firewall *forgets* about the packets

- **Weakness:** No knowledge of data moving between applications communicating across the network
 - Cannot protect against packet content, e.g. probes for specific software with vulnerabilities and exploit a buffer overflow for example
 - Should not be used to protect an organization’s infrastructure and information assets
- **Strengths:** Useful at the edge of a network to quickly and efficiently strip out obvious “junk” traffic
 - High performance and highly scalable because they do not carry out extensive processing on the packets and are not application dependent
 - First line of defense to block all network traffic that is obviously malicious or unintended for a specific network
 - Typically complemented with more sophisticated firewalls able to identify non-obvious security risks

Dynamic Packet-Filtering Firewalls

When an internal system needs to communicate with a computer outside its trusted network it needs to choose an identify its source port so the receiving system knows how/where to reply

- Ports up to 1023 are reserved for specific server-side services and are known as “well-known ports”
- Sending system must choose a randomly identified port higher than 1023 to use to setup a connection with another computer

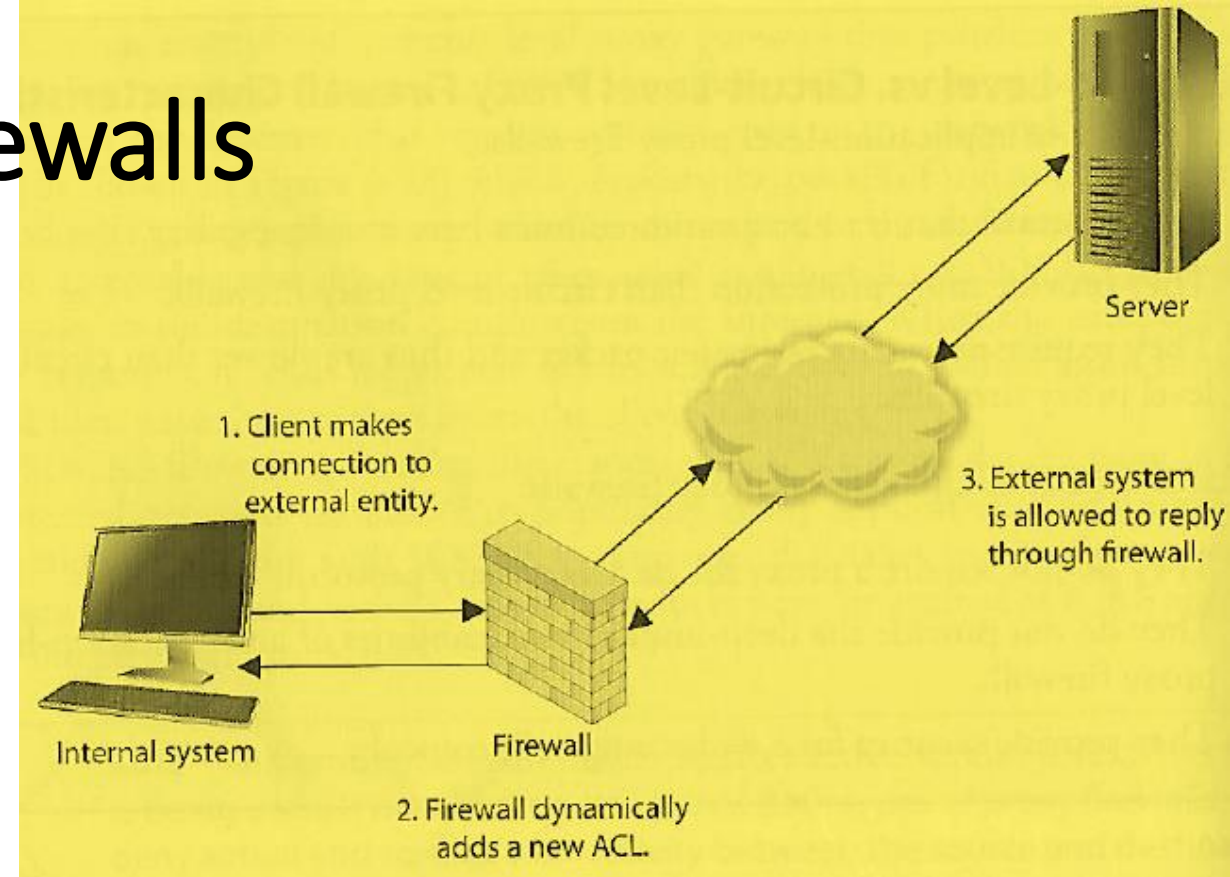

- The dynamic packet-filtering firewall creates an ACL that allows the external entity to communicate with the internal system via this high-numbered port
- The ACLs are dynamic in nature – once the connection is finished the ACL is removed
- The dynamic packet-filtering firewall offers the benefit of allowing any type of traffic outbound and permitting only response traffic inbound

Stateful Inspection Firewall

- Remembers and keeps track of what computers say to each other
 - Tracks where packets went until each particular connection between computers is closed
- Uses a “state table” which it updates to track the contents of packets each computer sent to each other
 - Makes sure the sequential process of packet message interchange involved in connection-oriented protocols (e.g. TCP – transmission control protocol) are properly synchronized and formatted
 - *If not an attack is detected and blocked*

Stateful Inspection example

Determine if all TCP Flags set to 1

- Attackers send packets with all TCP flags set to 1 with hope that the firewall will not understand or check these values and forward them to the server
- Under no circumstances during legitimate TCP connections are all values turned to 1
- If detected connection is blocked

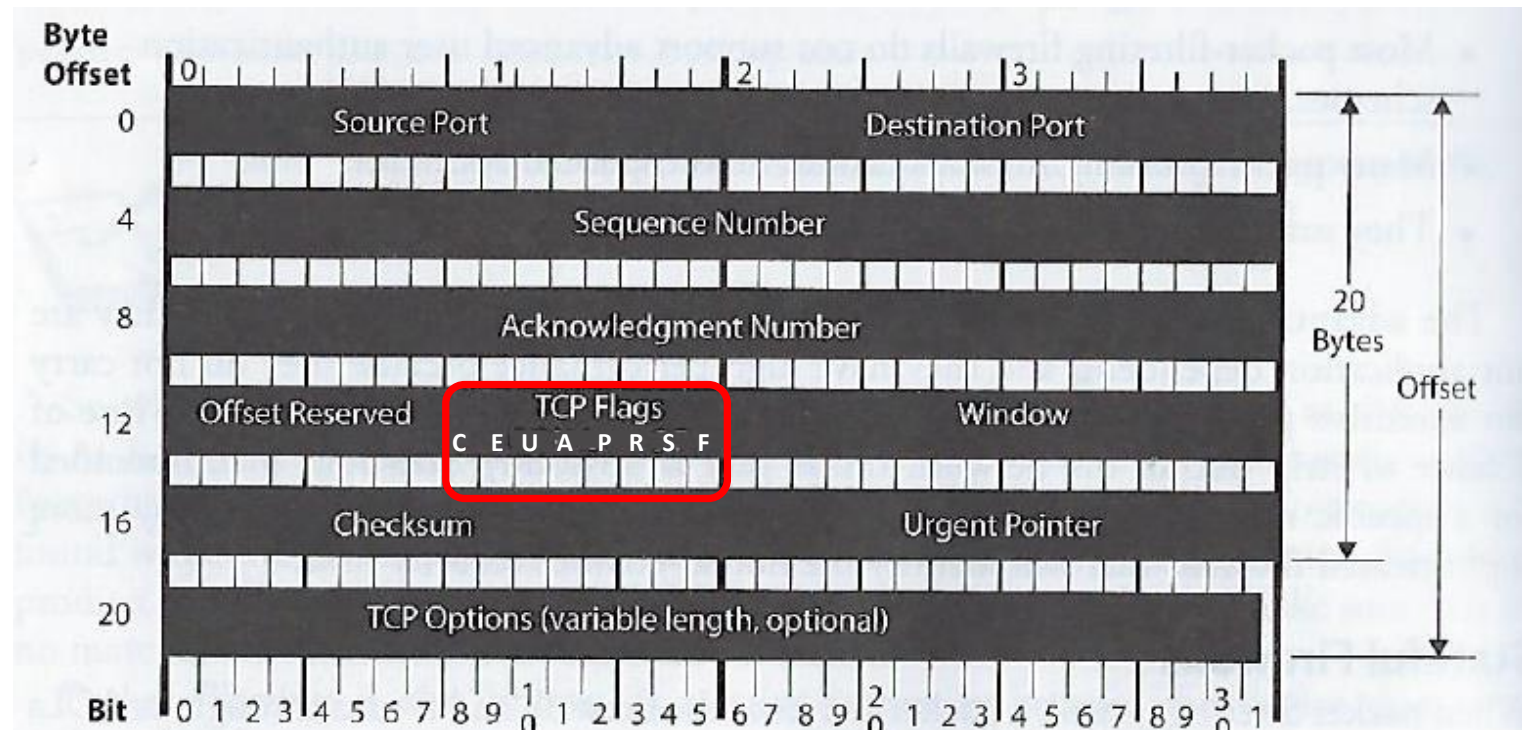

TCP Flags	
C	0x80
E	0x40
U	0x20
A	0x10
P	0x08
R	0x04
S	0x02
F	0x01

Congestion Window
C 0x80 Reduced (CWR)
E 0x40 ECN Echo (ECE)
U 0x20 Urgent
A 0x10 Ack
P 0x08 Push
R 0x04 Reset
S 0x02 Syn
F 0x01 Fin

Stateful Inspection example

Stateful inspection firewall assures that TCP (connection-oriented protocol) proceeds through a series of states:

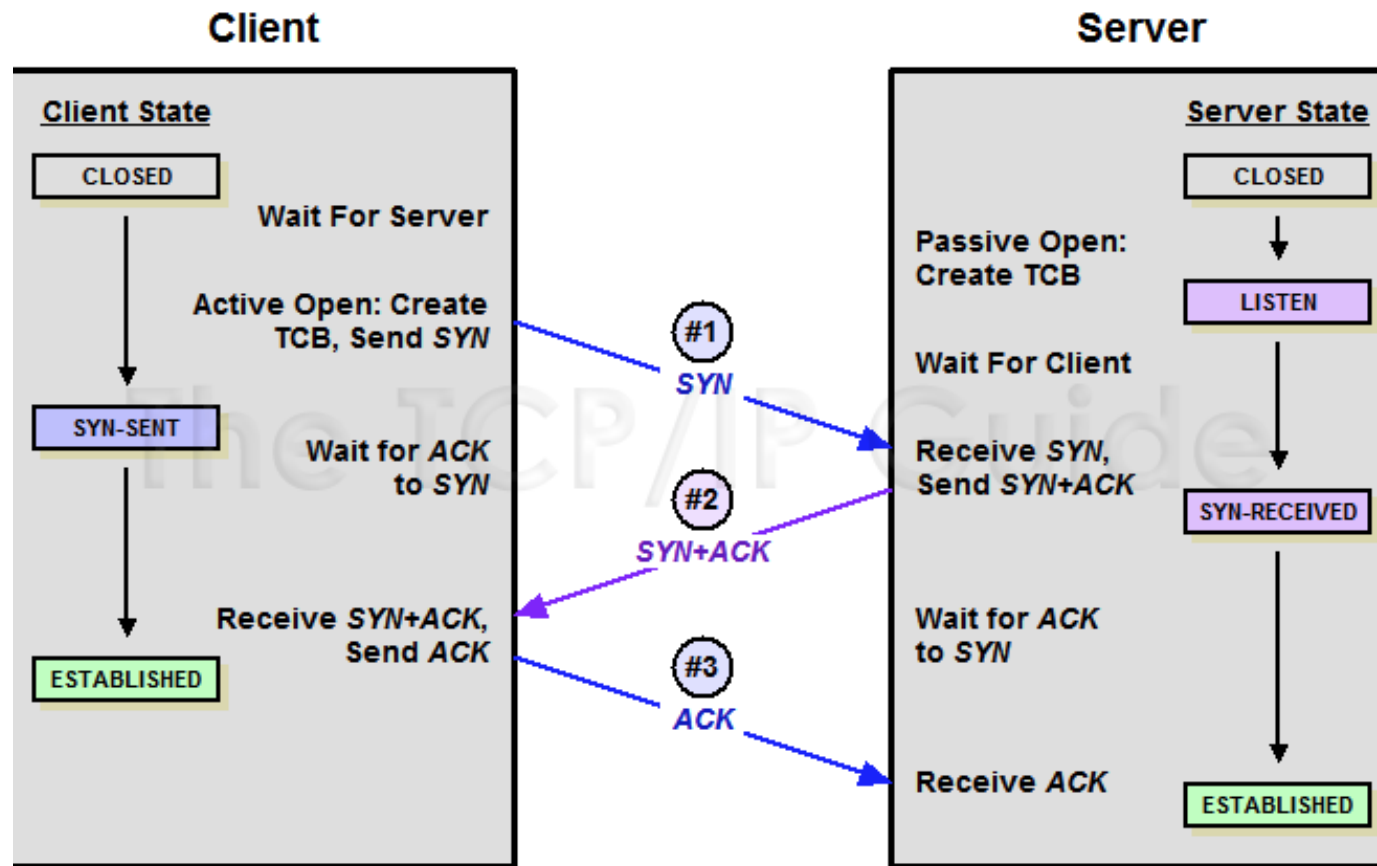

Stateful firewall keeps track of each of these states for each packet passing through, along with corresponding acknowledgement and sequence numbers

*Out of order acknowledgement and/or sequence numbers can imply a **replay attack** is underway and the firewall will protect internal systems from this activity*

Stateful Inspection Firewalls

Strength: Maintains a state table that tracks each and every communication session to validate the session

- Provides high-degree of security, without introducing a huge performance hit
- Is scalable and transparent to users
- Tracks both connection-oriented protocols (e.g. TCP) and connectionless protocols (UDP and ICMP)
- **Weakness:** Susceptible to Denial of Service (DoS) attacks aided at flooding the state table with fake information
 - *Poorly designed stateful firewalls with state-tables filled with bogus information may freeze or reboot*

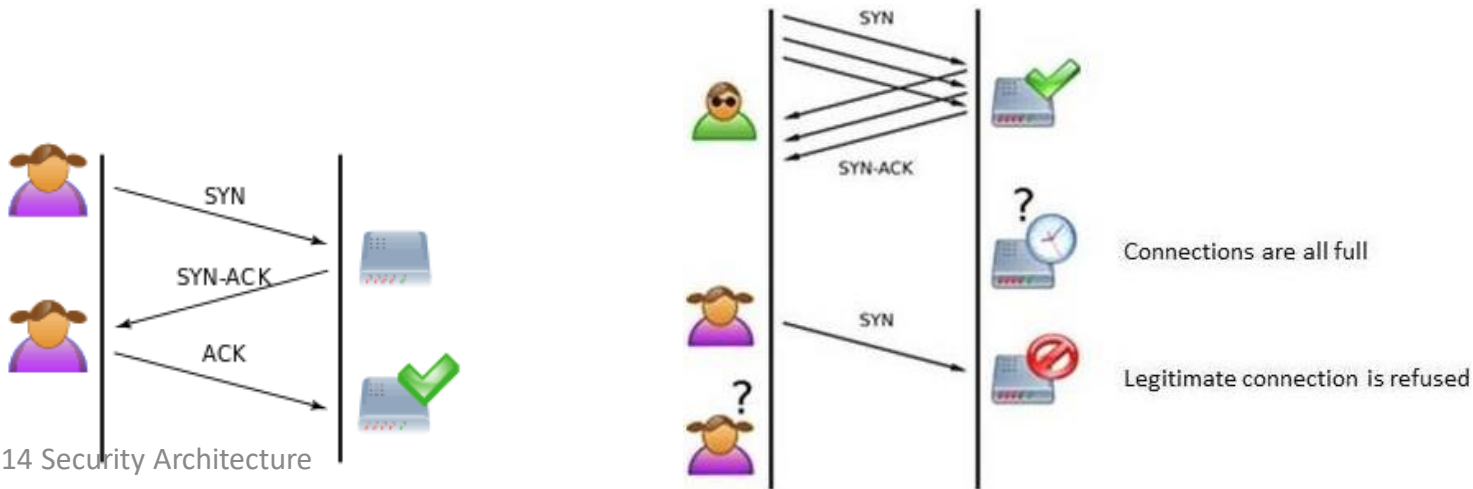

Proxy Firewall

Is a “middleman” standing between a trusted and untrusted networks, denying end to end connectivity between source and destination computers

Puts itself between the pair in both directions intercepting and inspecting each message before delivering it to the intended recipient

- Applies ACL rules, and also...
 - *Ends the communication session, breaking the communication channel between source and destination, so there is no direct connection between two communicating computers*
- *Inspects the traffic*
- *When traffic is “approved” the proxy firewall starts a new session from itself to the receiving system*

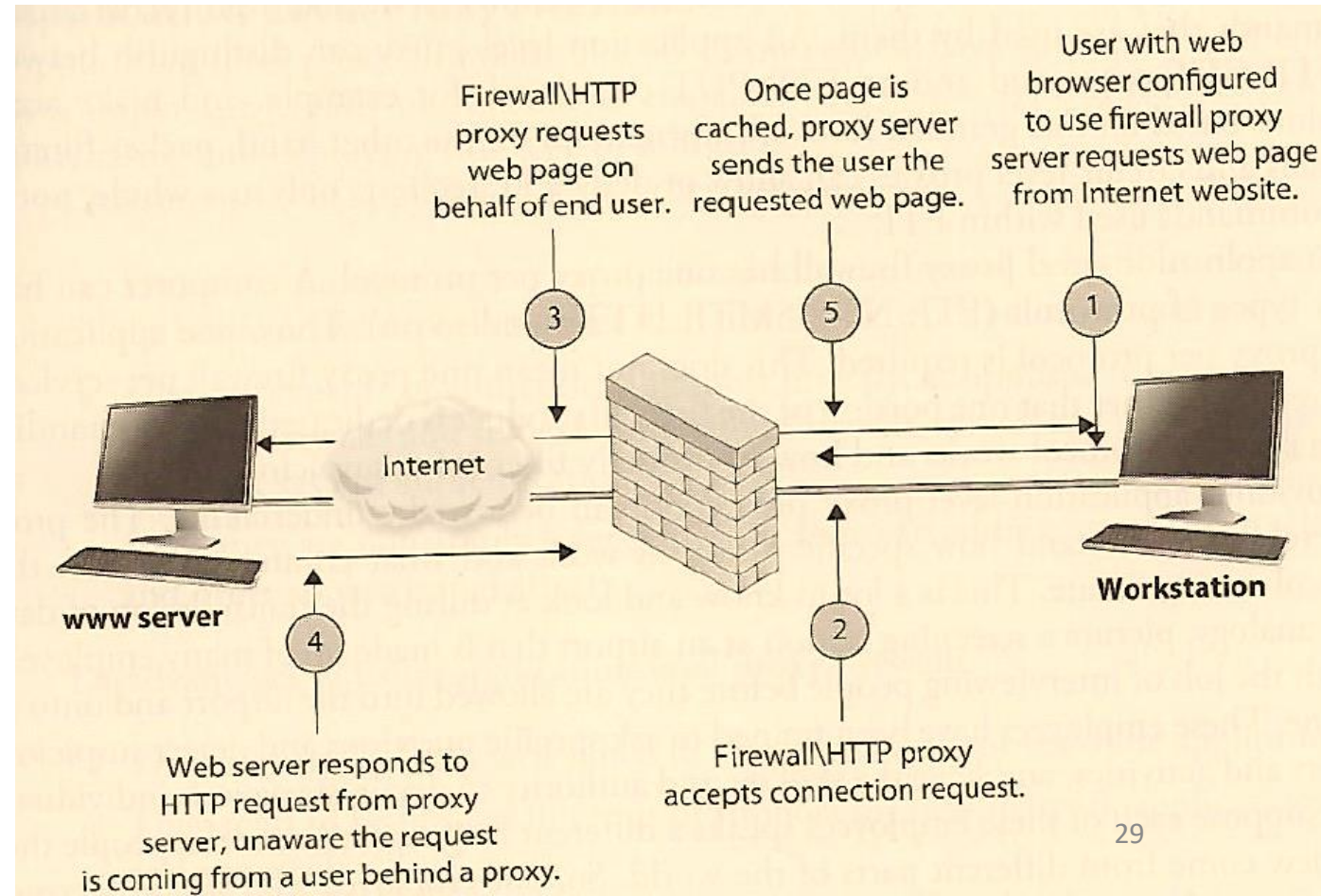

Application and Circuit Proxy Firewalls both

- Act as a proxy
- Deny actual end-to-end connectivity between the source and destination computers
- Clients attempting remote connection connects and communicates to the proxy; the proxy – in turn – establishes a connection to the destination system and makes requests to it on behalf of the client
- The proxy maintains 2 independent connections for every one network transmission, turning a 2-party session into a 4-party session – providing the middle processes emulating the 2 real systems

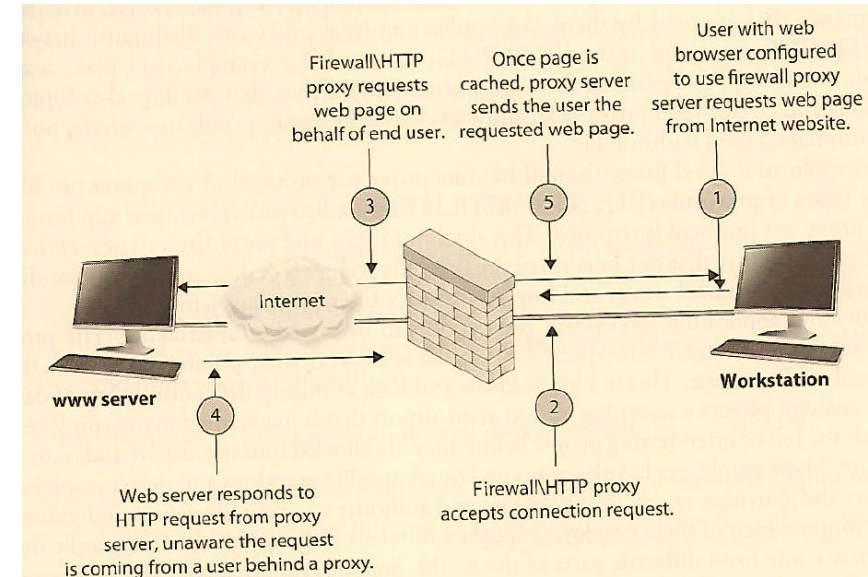

Proxy Firewall – two types working at different levels in the OSI model

- **Application-level proxies work up through Layer 7**
 - Understand entire contents of packets, making decisions based on API services, protocols and commands (e.g. FTP PUT and GET commands)
 - A Proxy Firewall will have a series of application-level proxies to detect suspicious data transmission – one proxy per API protocol (i.e. one for FTP, and different ones for SMTP, HTTP, ...)
- **Circuit-level gateways (proxies) work up through the session layer**
 - Monitor TCP handshaking between packets to determine whether a requested session is legitimate
 - Information passed to a remote computer appears to have originated from the gateway – hiding information about the protected private network
 - Firewall traffic rules control traffic to/from acknowledged computers only
 - Relatively inexpensive
 - Do not filter content of individual packets like application-level proxies do

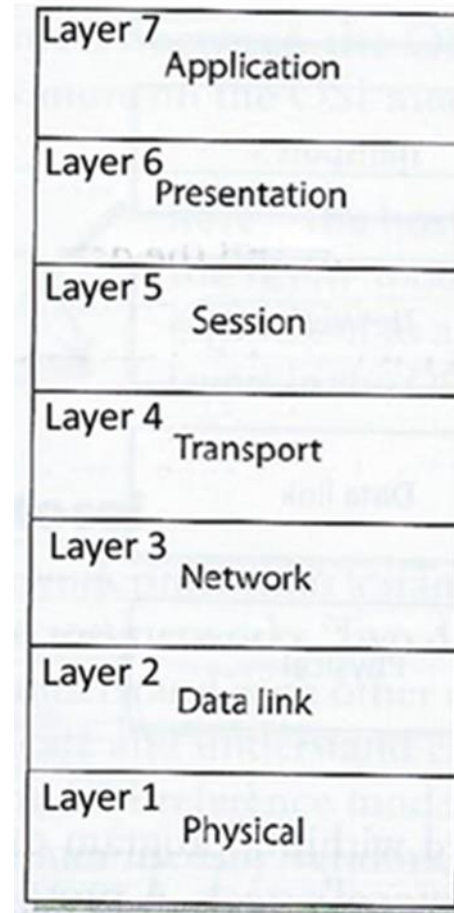

Circuit-level Proxy Firewalls

Only examines network addresses and ports – similar to packet filtering firewalls, but provides proxy services insulating the internal identities and addresses of machines from external devices

- Does not understand application-level protocols, and cannot provide more granular level control protecting from malicious transactions and content

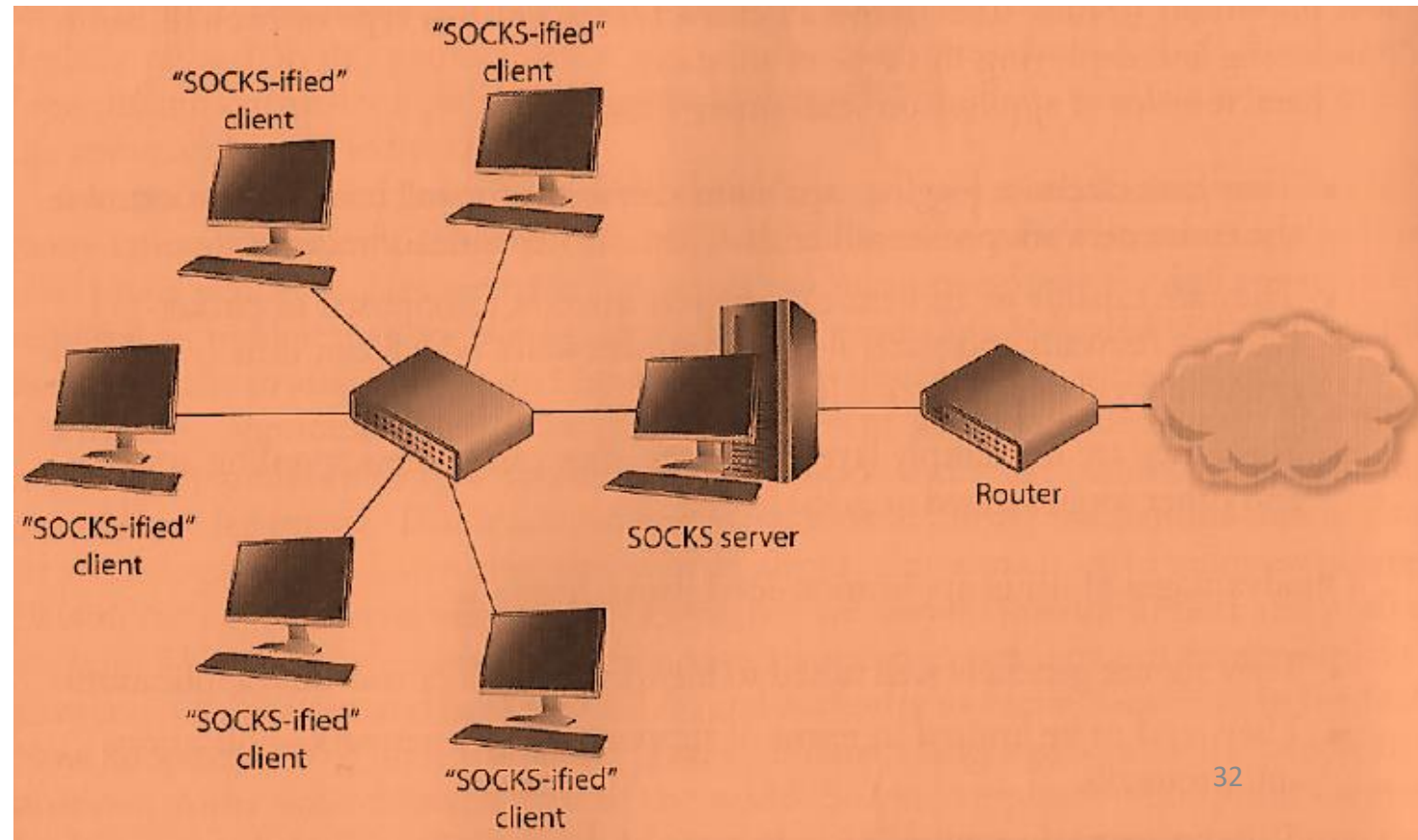

Application-level Proxy Firewalls

Advantages

- Have extensive logging capabilities that go hand-in-hand with ability to examine contents of the entire network packet rather than just addresses and ports
- Capable of authenticating users directly
 - Packet-filtering and stateful-inspection firewalls only able to authenticate systems (not users)
- Functioning a higher levels in the OSI stack enable them to detect and address spoofing and other sophisticated attacks

Disadvantages

- May not be well suited for real-time or high-bandwidth applications
- Create performance issues due to processing needed to inspect and analyze “deep content” of packets
- Limited support for newer network applications and protocols

Kernal Proxy Firewalls

- Considered a “fifth generation” firewall
- Functions as a proxy – conducting network address translation so it function as a “middleman”
- Creates a dynamic, customized virtual network stacks for each packet that consists of only the protocol proxies needed to examine it
 - The packet is evaluated at every layer of the stack simultaneously
 - Data link header
 - Network header
 - Transport header
 - Session layer information
 - Presentation layer information
 - Application layer data
 - If anything is determined unsafe the packet is discarded
- Much faster than an application-level proxy because it is optimized to function at the lower level kernel level of the operating system

Next-Generation Firewalls (NGFW)

- Combines the best capabilities of the other firewalls
 - Ensures traffic is well-behaved and in accordance with applicable protocols
 - Breaks direct connection between internal and external systems (proxy)
 - Provides dynamic port assignment
- Also includes a signature-based Intrusion Detection System (IPS) engine
 - Able to look for specific indicators of attack even in traffic is well behaved
- Able to use centralized data sources
 - Able to be updated with new attack signatures from cloud aggregators
 - For consistent up to date whitelists, blacklists and policies
 - Can connect to Active Directory to provide URL to IP address translations
- Tend to be expensive – cost of ownership beyond small and medium sized organizations

Summary

Firewall type	OSI Layer	Characteristics
Packet Filtering	Network Layer	Looks at destination and source addresses, ports, and services requested. Routers use ACLs monitor network traffic
Dynamic Packet Filtering	Network Layer	Allows any permitted type of traffic outbound and only response traffic inbound
Stateful	Network Layer	Looks at the state and context of packets. Keeps track of each conversation using state table
Circuit-level Proxy	Session Layer	Provides proxy services, but looks only at the header packet information (less detailed level of control that application-level proxy)
Application-level Proxy	Application Layer	Looks deep into packets and makes granular access control decisions, It requires one proxy per protocol
Kernal Proxy	Application Layer	Faster than application-level proxy because processing performed in operating system kernel. One network stack created for each packet
Next-generation	Multiple Layers	Very fast and supports high bandwidth. Built-in IPS, able to connect to external services like Active Directory

Some Firewall Architecture Patterns based on firewall placement

1. Bastion host
2. Dual-homed Firewall
3. Screened host
4. Screened Subnet

Bastion Host

- Bastion host system is a highly exposed device closer than any other system to an untrusted network, that is most likely to be targeted by attacker
- A special-purpose computer on a network specifically designed and configured to withstand attacks. The computer generally hosts a single application, for example a proxy server, and all other services are removed or limited to reduce the threat to the computer
- Typically directly connected to an untrusted network, or placed inside DMZ
- Needs to be extremely locked down and hardened to reduce its attack surface (i.e. vulnerabilities reduced as much as possible):
 - All unnecessary:
 - Services disabled
 - Accounts removed
 - Applications removed
 - Subsystems and administrative tools removed

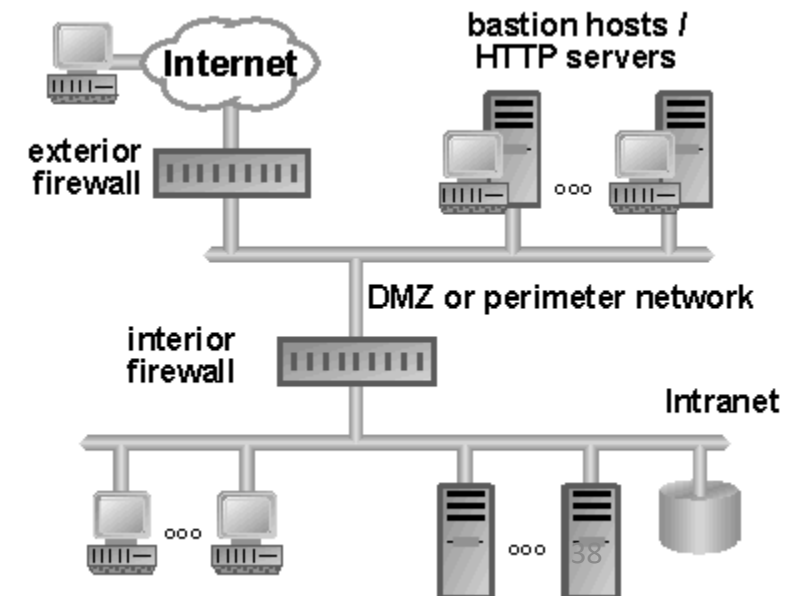

Characteristics of Firewall Architecture

- **Dual-homed**

- A single computer with separate NICs connected to internal and external network
- Used to divide an external untrusted network from an internal trusted network
- Must harden and disable computer's forwarding and routing functionality so the two networks communicate through the computer's firewall software and are truly segregated

- **Screened host**

- A router filters and screens traffic applying its ACL to drop 'junk' traffic before it is passed to the firewall

- **Screened subnet**

- An external router filters/screens traffic before it enters the subnet, sending remaining traffic through two firewalls before making its way to the internal network

Dual-Homed Firewall Architecture

- A “dual-homed” device has two network interface cards (NICs)
 - Multi-homed devices have multiple NICs
- Firewall software running on a dual-homed device
 - Underlying operating system should have packet forwarding and routing turned off for security
- Packet comes to the external NIC from an untrusted network and is forwarded up through the firewall software and if not dropped forwarded to the internal NIC
- Without redundancy, if this goes down the dual-homed firewall becomes a single point of failure
- One layer of protection lacks “defense in depth”
If an attacker compromises one firewall they can gain direct access to the organizations network resources

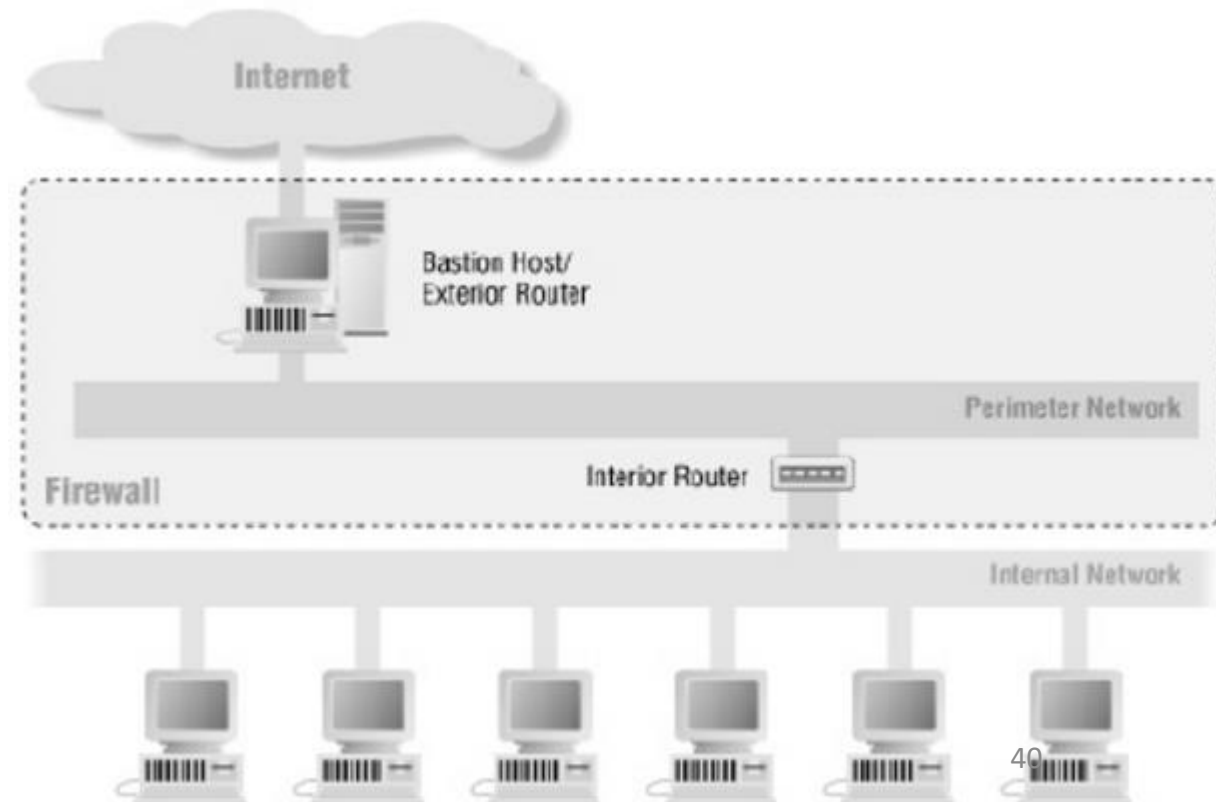

Screened Host Firewall Architecture

A firewall that communicates directly with a perimeter router and the internal network

1. Traffic from the Internet first passes through a packet filtering router applying ACL rules which filters out (i.e. drops) junk packets
 2. Traffic that makes it past this phase is sent to the screen-host firewall which applies more rules to the traffic and drops the denied packets
 3. Remaining traffic moves to the internal network
- Router provides network-level packet filtering
 - Application-based firewall provides packet filtering at the application layer
 - Security level is higher than a bastion dual-homed firewall because attacker would need to compromise 2 systems to succeed

“One-tier tiered configuration”

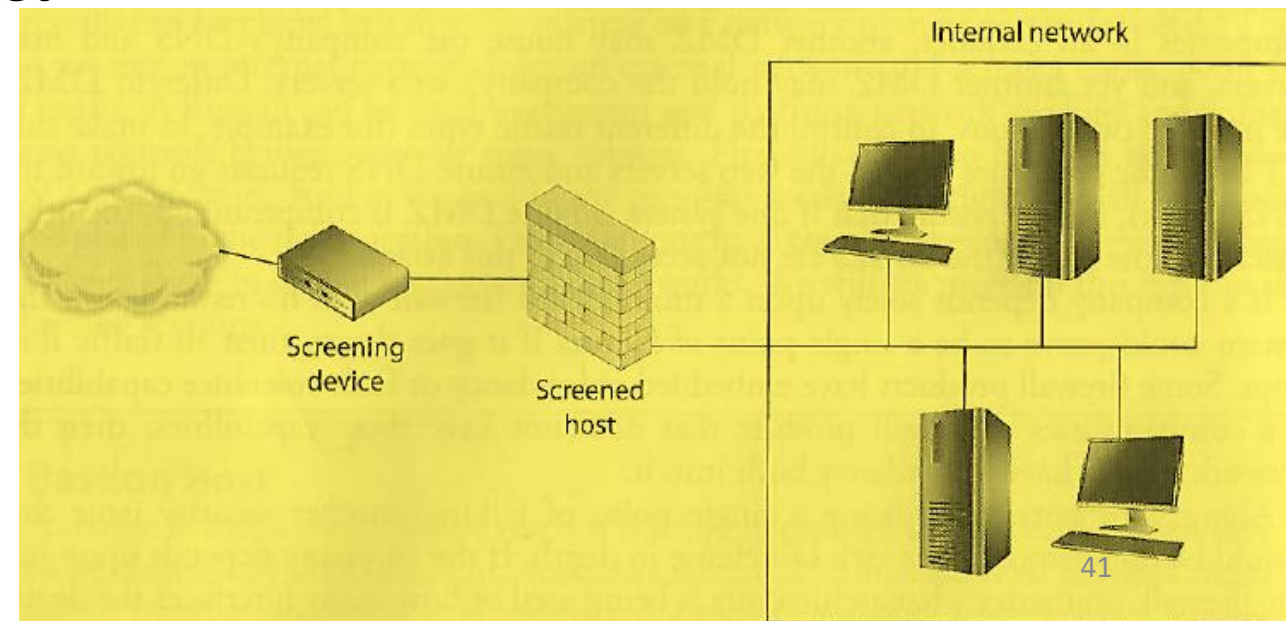

Screened Subnet Architecture

Adds another layer of depth to the security of the screened-host architecture

- The external firewall screens traffic entering the screened sub-network, instead of firewall redirecting traffic to the internal network
- The second interior firewall also filters the traffic – this creates a screened subnet (i.e. DMZ)

Creates a DMZ between 2 firewalls which functions as a small network isolated between trusted internal and untrusted external network

3-devices working together provides more protection than a stand-alone firewall or a screened-host firewall

All 3 need to be compromised by an attacker to gain access to the internal network

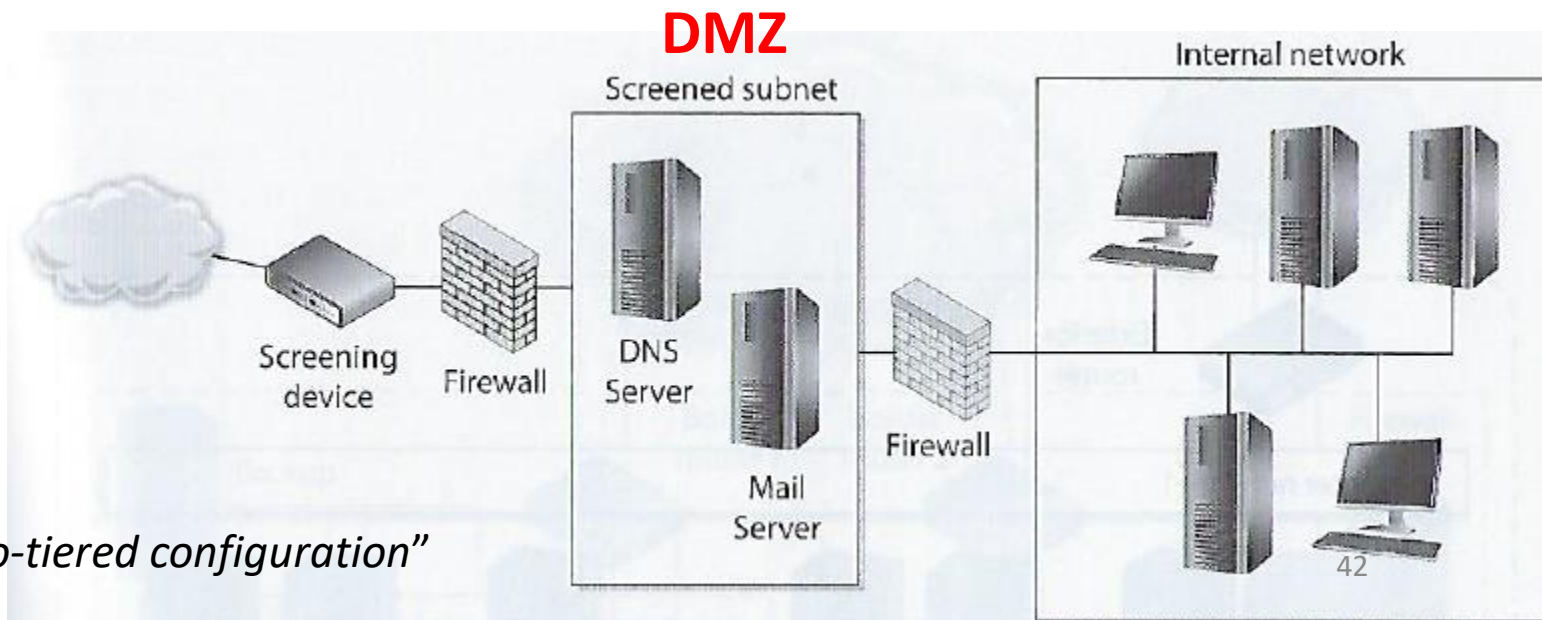

Demilitarized Zone (DMZ)

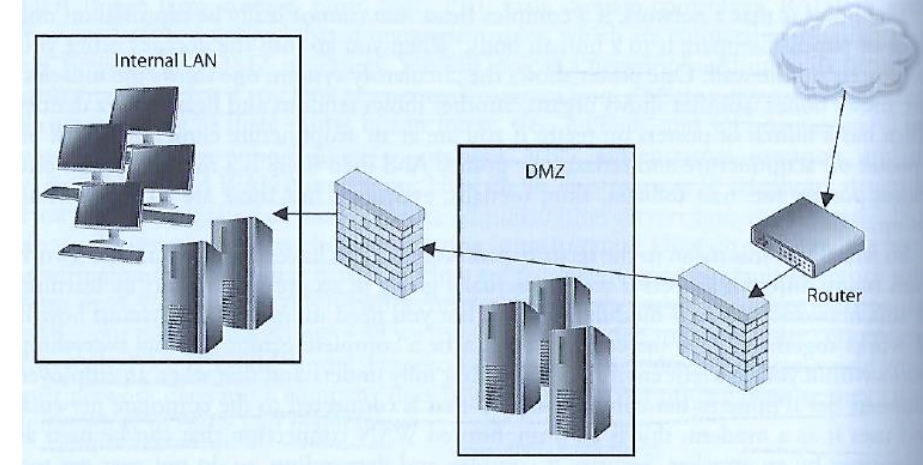

Firewalls are installed to construct DMZ areas

- Network segments which are located between protected and unprotected networks
- Provides a buffer zone between the dangerous Internet and valuable assets the organization seeks to protect
- Usually 2 firewalls are installed to form a DMZ
 - May contain mail, file, and DNS (Domain Name System) servers
 - Usually contain an Intrusion Detection System sensor which listens for suspicious and malicious behavior
 - Servers in DMZ must be hardened to serve as the first line of protection against attacks coming from the internet

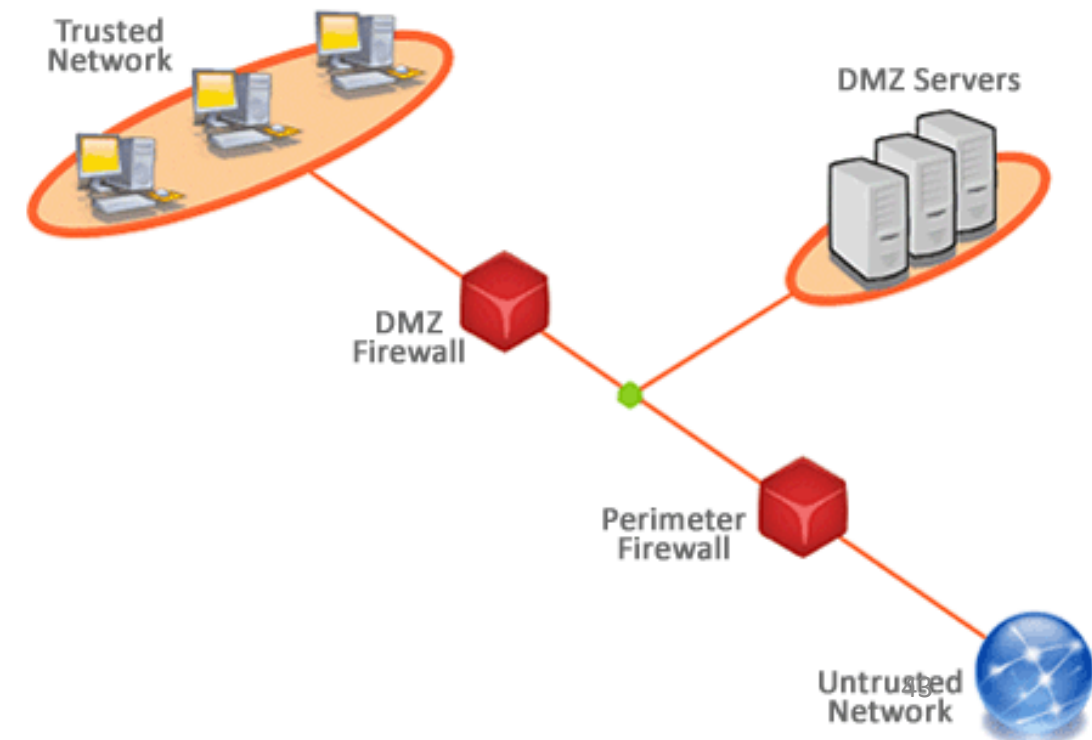

Firewalls have rules...

- Good firewall behavior: ***default action is to deny*** any packets explicitly not allowed
 - If no rule in the ACL explicitly says the packet can come in, it is dropped
 - Any packet coming in from the Internet containing the source address of an internal host should be dropped
 - Spoofing or masquerading attack reflected in a modified packet header having the source address of a host inside the target network
 - No packet should be permitted to leave that does not contain a source address of an internal host – this is how DDoS zombies work
 - Many companies deny packets with source routing information in the headers which may circumnavigate internal routers and firewalls
- Firewalls ***not effective “out of the box”***
 - Need to understand internal default rules which may negate user provided rules
 - Can create bottlenecks
 - Need to effectively distribute them throughout the network to control network access points and provide appropriate “defense in depth”
 - Do not protect against malware, complex attack types, sniffers, rogue access points

Internet Geolocation

- Internet geolocation is software capability for deducing the geographic position of a device connected to the Internet
 - For example, the device's IP address can be used to determine the country, state, city, or ZIP code
- There are free and paid subscription geolocation databases that range from country level, state, city, or zip-code
- The primary source for IP address data is the regional Internet registries which allocate and distribute IP addresses amongst organizations located in their respective service regions:
 - African Network Information Centre (AfriNIC)
 - American Registry for Internet Numbers (ARIN)
 - Asia-Pacific Network Information Centre (APNIC)
 - Latin American and Caribbean Internet Address Registry (LACNIC)
 - RIPE Network Coordination Centre (RIPE NCC)
- GeoIP – Database capability for looking up IP address and returning a mappable location latitude and longitude

Temple University's IP addresses

- E.g. 155.247.164.29

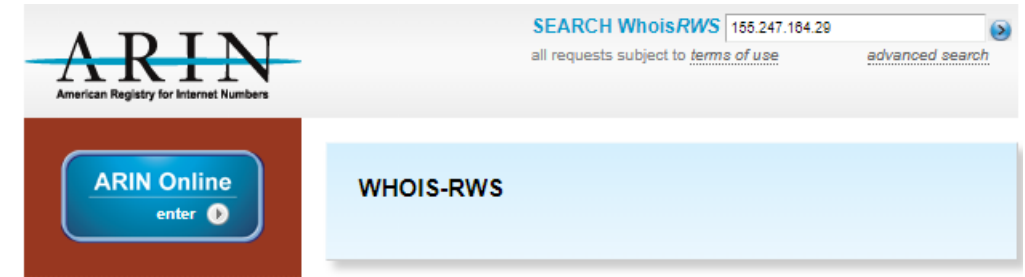

ARIN
American Registry for Internet Numbers

SEARCH WhoisRWS 155.247.164.29
all requests subject to [terms of use](#) [advanced search](#)

ARIN Online
enter

WHOIS-RWS

Point of Contact	
Name	Temple University Computer Services Abuse Contact
Handle	TUCSAC-ARIN
Company	Temple University
Street	3rd floor Telecommunications 1101 W Montgomery Avenue
City	Philadelphia
State/Province	PA
Postal Code	19122
Country	US
Registration Date	2014-04-30
Last Updated	2021-04-30
Comments	
Phone	+1-215-204-8000 (Office)
Email	abuse@temple.edu
RESTful Link	https://whois.arin.net/rest/poc/TUCSAC-ARIN

<https://whois.arin.net/rest/net/NET-155-247-0-0-1/pft?s=155.247.164.29>

Geo-blocking

- Technology that restricts access to Internet content based on user's geographical location

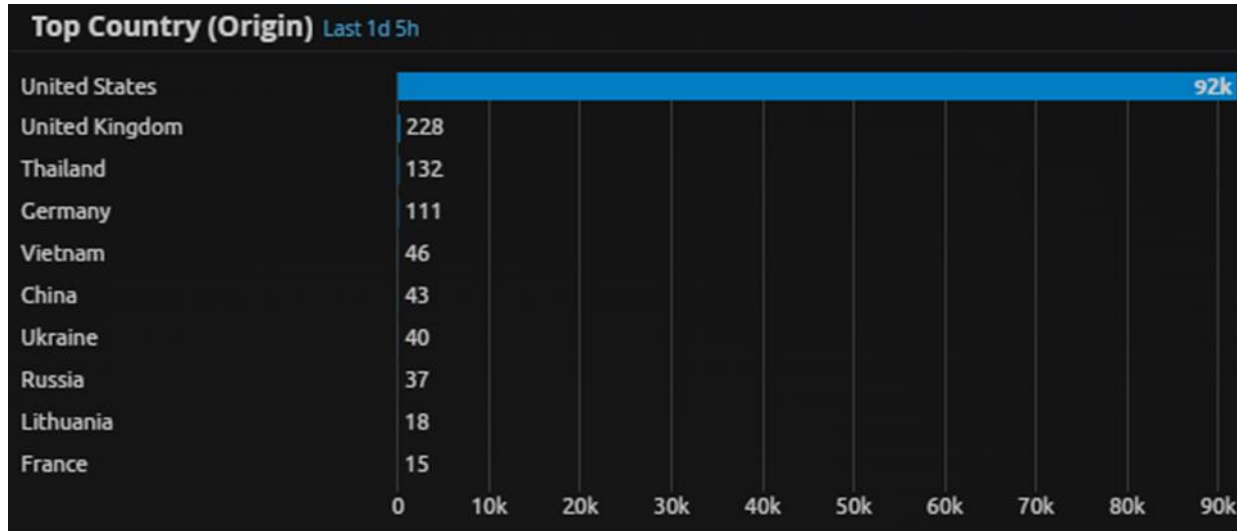

AbuseIPDB » 88.80.186.144

Check an IP Address, Domain Name, or Subnet
e.g. 98.124.160.253, microsoft.com, or 5.188.10.0/24

88.80.186.144 was found in our database!

This IP was reported 1,099 times. Confidence of Abuse is 100%: ?

100%

ISP Linode LLC
Usage Type Data Center/Web Hosting/Transit
Hostname(s) 88-80-186-144.ip.linodeusercontent.com
Domain Name linode.com
Country United Kingdom of Great Britain and Northern Ireland
City London, England

IP info including ISP, Usage Type, and Location provided by IP2Location. Updated monthly.

[REPORT 88.80.186.144](#)

[WHOIS 88.80.186.144](#)

IP Abuse Reports for 88.80.186.144:

This IP address has been reported a total of 1,099 times from 316 distinct sources. 88.80.186.144 was first reported on November 2nd 2021, and the most recent report was 22 minutes ago.

Recent Reports: We have received reports of abusive activity from this IP address within the last week. It is potentially still actively engaged in abusive activities.

Reporter	Date	Comment	Categories
Anonymous	22 minutes ago	HACKER	Brute-Force
bSebring	24 minutes ago	02/14/2022-14:32:53.885234 88.80.186.144 Protocol: 6 ET SCAN Rapid IMAP Connections - Possible Brute ... show more	Hacking
bSebring	24 minutes ago	02/14/2022-14:32:47.896526 88.80.186.144 Protocol: 6 ET SCAN Rapid POP3 Connections - Possible Brute ... show more	Hacking
bSebring	24 minutes ago	02/14/2022-14:32:46.030949 88.80.186.144 Protocol: 6 ET SCAN Rapid IMAP Connections - Possible Brute ... show more	Hacking

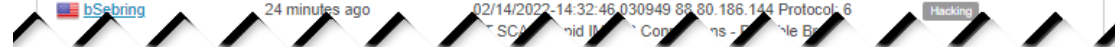

Common firewall rules:

Stealth rule

Disallow unauthorized systems from accessing the firewall software

Silent rule

Identify and drop “noisy” traffic without logging it to reduce log sizes by not responding to unimportant packets

Cleanup rule

Last rule in the rule base drops and logs remaining traffic that does not meet preceding rules

Negate rule

Create tighter rules by specifying what system can be accessed and how (whitelisting), and do not use broad and permissive rules that default to any traffic (e.g. blacklisting)

Agenda

- ✓ Introduction
 - ✓ Physical “air-gap” security and how we undermined it
- ✓ Firewalls
 - ✓ Types of firewalls
 - ✓ Some architectural patterns based on firewall placement
 - ✓ Firewalls have rules
- Intrusion Detection System (IDS) & Intrusion Prevention System (IPS)
- Defense in Depth with security zones (“Security Domains”)
- Project Team Assignment
- Preparation for Mid Term Exam

Intrusion Detection Systems (IDSs)

While firewalls and antivirus are preventive controls, IDSs are access control monitoring devices designed to

1. Detect a security breach
2. Aid in mitigating damage caused by hackers breaking into sensitive computer and network systems

• IDS' components

1. Sensors
 - Collect and send traffic and user activity data to analyzers
2. Analyzers
 - Look for suspicious activity and if found sends alert to administrator's interface
3. Administrative interfaces

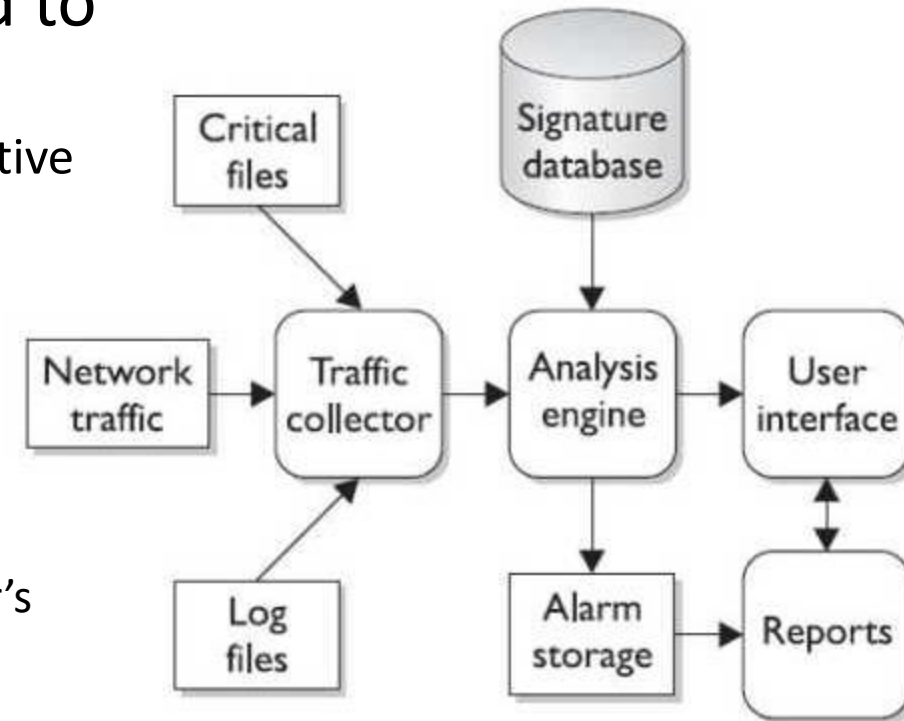

Intrusion Detection Systems (IDSs)

Two main types of IDS

1. **Host-based** for analyzing activity within a particular computer system
2. **Network-based** for monitoring network communications

IDS can be configured to:

- Watch for attacks
- Parse audit logs
- Terminate a connection
- Alert administrator as attacks happen
- Expose a hacker and her/his techniques
- Illustrate which vulnerabilities need to be addressed

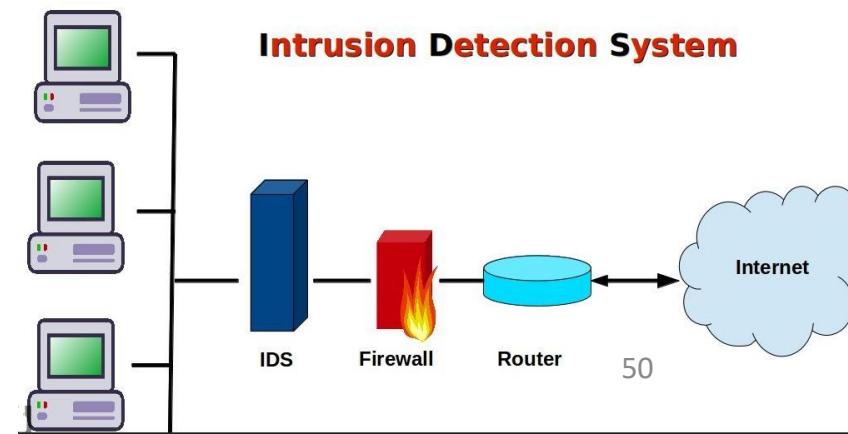

Intrusion Detection Systems (IDSs)

Host-based IDS (HIDS)

- Can be installed to look at the data packets within the higher levels of the OSI stack for anomalous or inappropriate activity on individual servers and/or workstations
- Usually installed on critical servers (too much administrative overhead to put them everywhere)
- Make sure users do not put the system at risk by activities such as deleting system files or reconfiguring important settings
- Does deeper inspection of the packets
- Does not understand network traffic

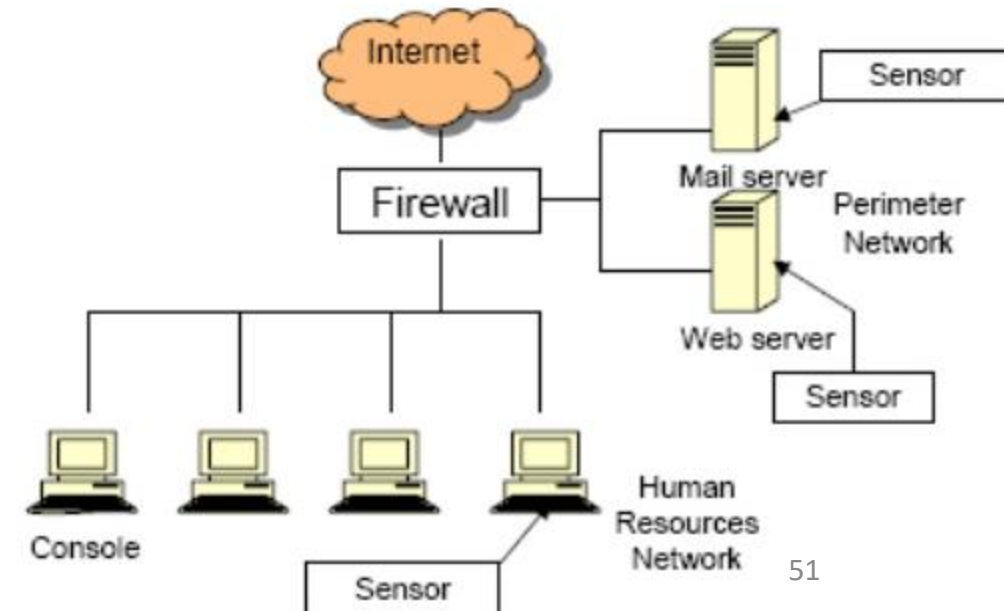

Intrusion Detection Systems (IDS)

Network-based IDS (NIDS)

- Uses sensors which can be either host computers with specialized software installed or dedicated appliances
 - Each have a NIC (network interface card)
 - NIC is configured in promiscuous mode to capture all traffic (rather than packets addressed to the host computer)
 - Copies packets – sending one copy up the TCP stack (for normal processing or possible analysis with a HIDS), and another copy to analyzer looking for specific patterns in the network traffic
- Monitors network traffic, cannot see the activity happening within the higher levels of the OSI stack (HIDS is used for this)

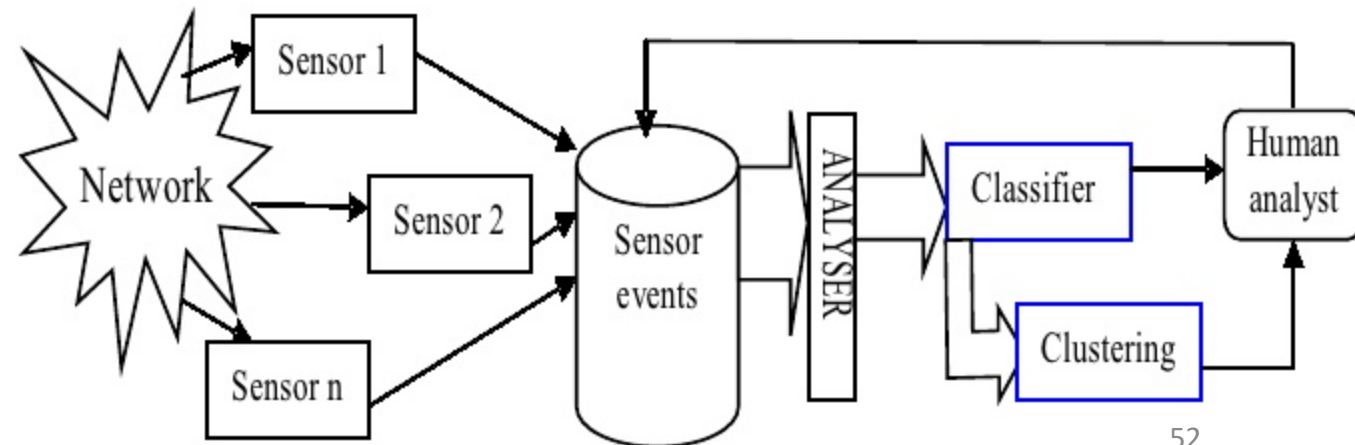

Intrusion Detection Systems (IDS)

NIDS and HIDS can be one of the following types:

1. Signature-based:

- Pattern matching, similar to antivirus software
- Signatures must be continuously updated
- Cannot identify new attacks
- 2 types
 - Pattern matching: Compares individual packets to signatures
 - Stateful matching: Compares patterns among packets

2. Anomaly-based (a.k.a. Heuristic-based or Behavior-based):

- Behavioral-based system able to learn from “normal activities”
- Can detect new attacks
- 3 Types:
 - Statistical anomaly-based – creates a normal profile used to compare sensed activities
 - Protocol anomaly-based – Identifies incorrect uses that violate protocols (e.g. TCP 3-way handshake)
 - Traffic anomaly-based – Identifies unusual activity in network traffic

3. Rule-based

- Uses artificial intelligence expert systems that process rules in the form of “If *situation* then *action*” statements to identify combinations of activities within the data of the packets
 - e.g. “IF a root user creates FileA AND FileB IN same directory and there is a call to Administrative ToolK THEN trigger alert”
- Cannot detect new attacks
- The more complex the rules, the greater the need for processing power to support the software and hardware requirements so the IDS does not become a bottleneck and performance problem

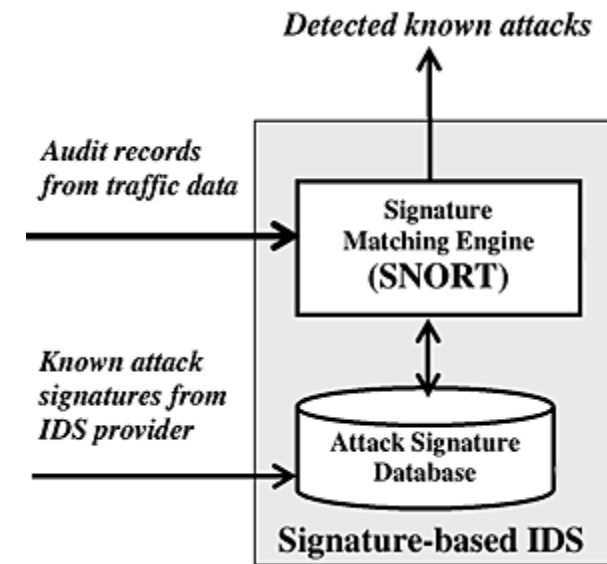

Network IDS Rule Examples

- Detect port scans on the network
 - *A port scanner is an application designed to probe a server or host for open ports. Such an application may be used by attackers to identify network services running on a host and exploit vulnerabilities*
- Detect vulnerable versions of software on the network
 - *E.g. software that is older than the current version*
- Detect shells
 - *Detects forward and reverse command shells that are transmitted in cleartext across the network*
- Detect vulnerable protocols
 - *Detect sessions on the network in various protocols, e.g. ftp, http, rdp, ...*
- Detect brute-forcing
 - *Detects brute force attacks performed by hosts that are guessing passwords over SSH*
- Detect SQL injection
 - *Determines if a host is performing a SQL injection attack*
- Detect SSH attack
 - *Detects SSH password guessing if a SSH password attempt is generated e.g. 3 times within 60 minutes*
- Detects data exfiltration
 - *Watches particular hosts or subnetworks and determines if data files are being moved off the network outside of business hours*
- Detect nodes on network transmitting or receiving large amounts of data
 - *Good for possibly finding malware, bitcoin mining, data theft,*
- Detect Credit Cards
 - Looks for credit card information sent across the network in plaintext
- Detect Passwords
 - Looks for clear text passwords sent over HTTP protocol

Intrusion Prevention Systems (IPS)

IDS – Detect something bad may be taking place and send an alert

Detective and “after the fact” response

- IPS – Detect something bad may be taking place and block traffic from gaining access to target
 - *Preventive and proactive response*
 - *IPS can be host-based or network-based (like IDS)*
 - *Can be content-based (looking deep into packets), conduct protocol analysis or be signature matching*
 - *Also can use rate-based metrics to identify suspicious increases in volumes of traffic*
 - *E.g. DoS – flood attack*
 - *Traffic flow anomalies – “slow and low” stealth attack attempting to be undetected*

IDS versus IPS

Possible responses to a triggered event:

- Disconnect communications and block transmission of traffic
- Block a user from accessing a resource
- Send alerts of an event trigger to other hosts, IDS monitors and administrators

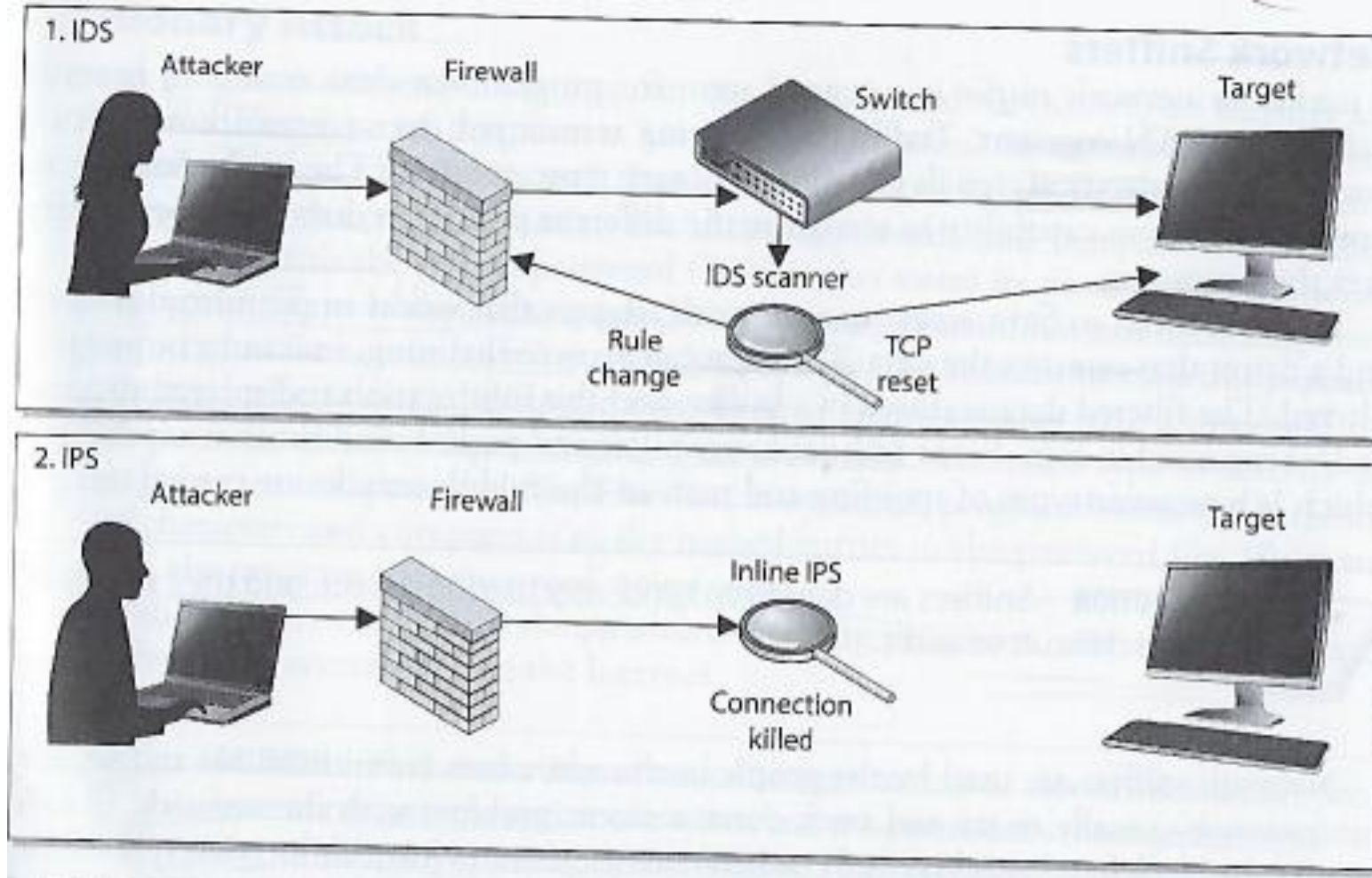

Agenda

- ✓ Introduction
 - ✓ Physical “air-gap” security and how we undermined it
- ✓ Firewalls
 - ✓ Types of firewalls
 - ✓ Some architectural patterns based on firewall placement
 - ✓ Firewalls have rules
- ✓ Intrusion Detection System (IDS) & Intrusion Prevention System (IPS)
 - Defense in Depth with security zones (“Security Domains”)
 - Project Team Assignment
 - Preparation for Mid Term Exam

Zone 1: External connectivity to the Internet, peer locations, and back-up facilities

Zone 2: External connectivity for corporate communications

Zone 3: Control systems communications from external services

Zone 4: Control systems operations – process based or SCADA

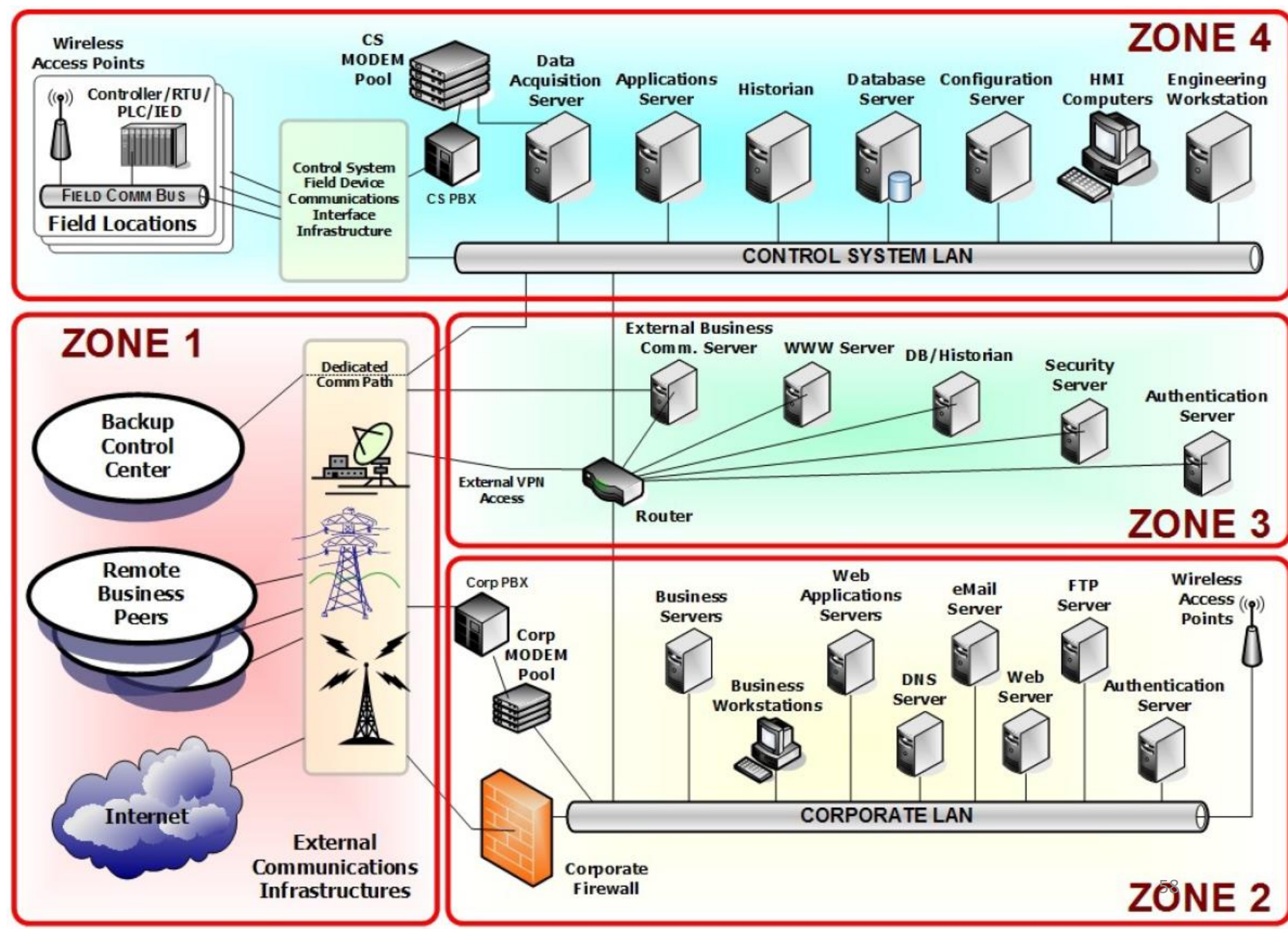

Attack scenarios suggest...

- Intrusions begins at some point outside the control zone, and attacker pries deeper and deeper into the architecture
- Securing each core zone creates a defensive strategy with depth

- Offering administrators more opportunities for information and control of resources
- Introduces cascading countermeasures that will not necessarily impede business functionality

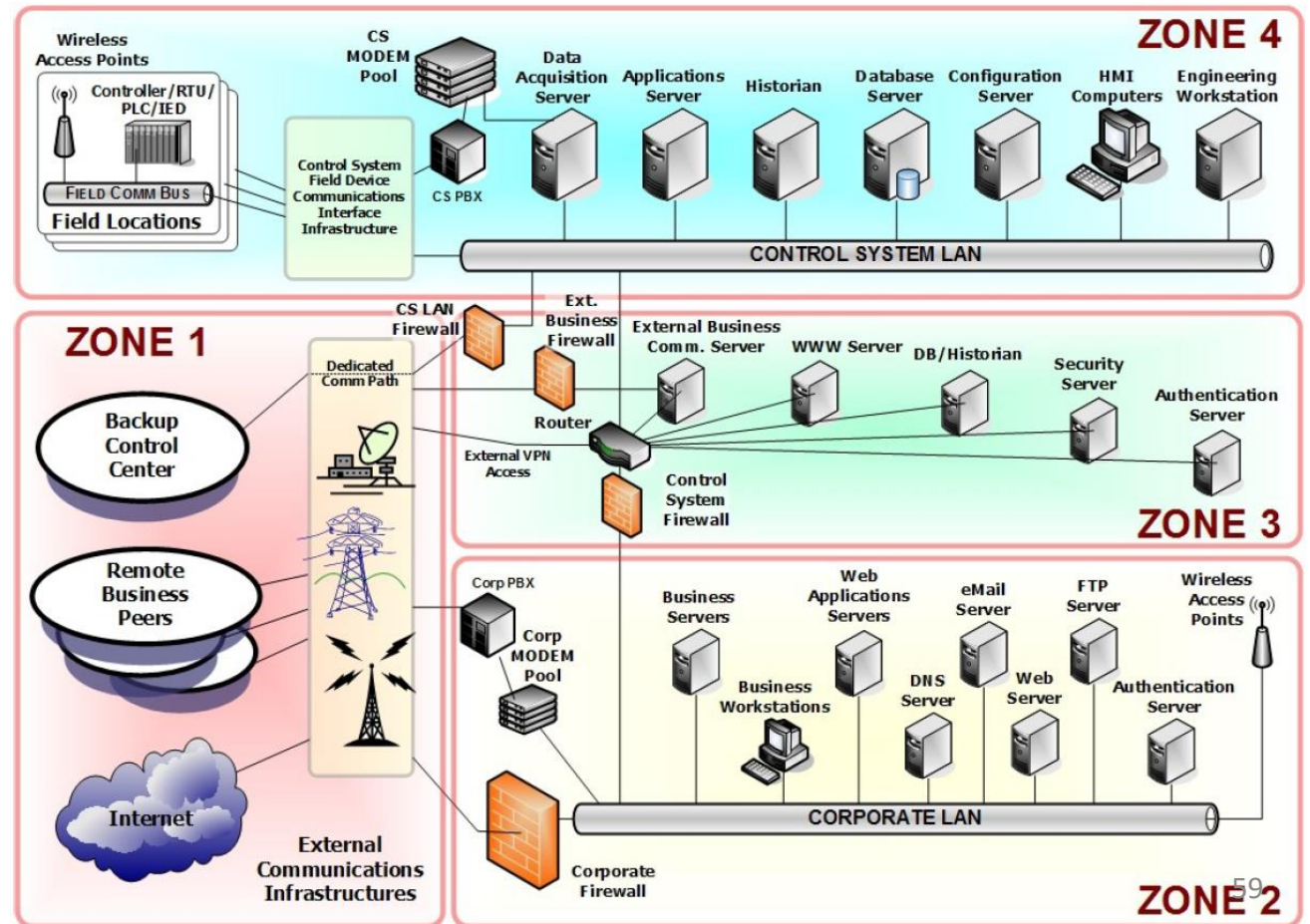

Firewalls DMZ deployments

“Control Systems Cyber Security: Defense in Depth Strategies”, Prepared by Idaho National Laboratory’s Control Systems Security Center, for U.S. Department of Homeland Security, External Report# INL/EXT-06-11478, May 2006

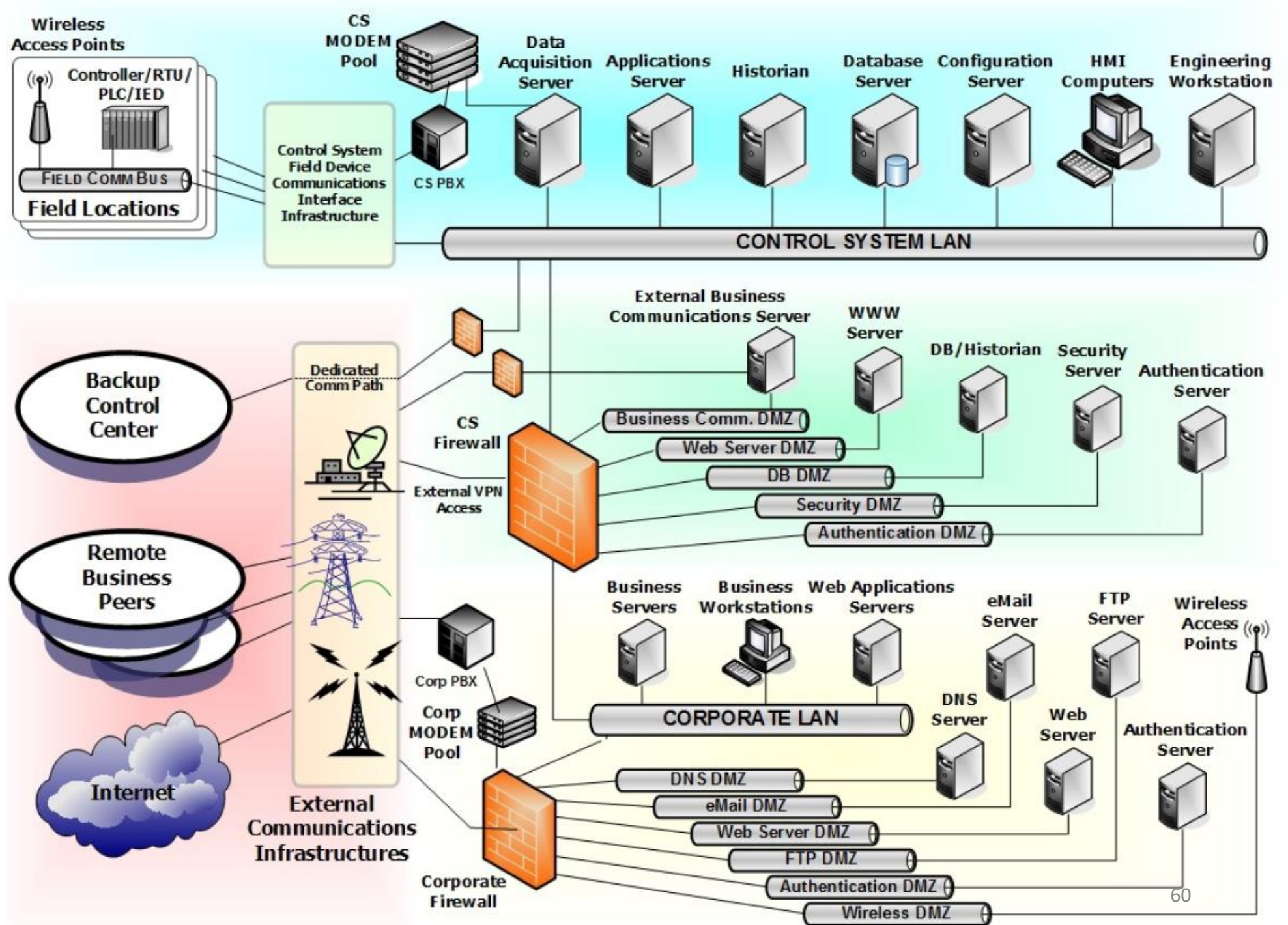

*Intrusion Detection
System Sensors located
throughout the network*

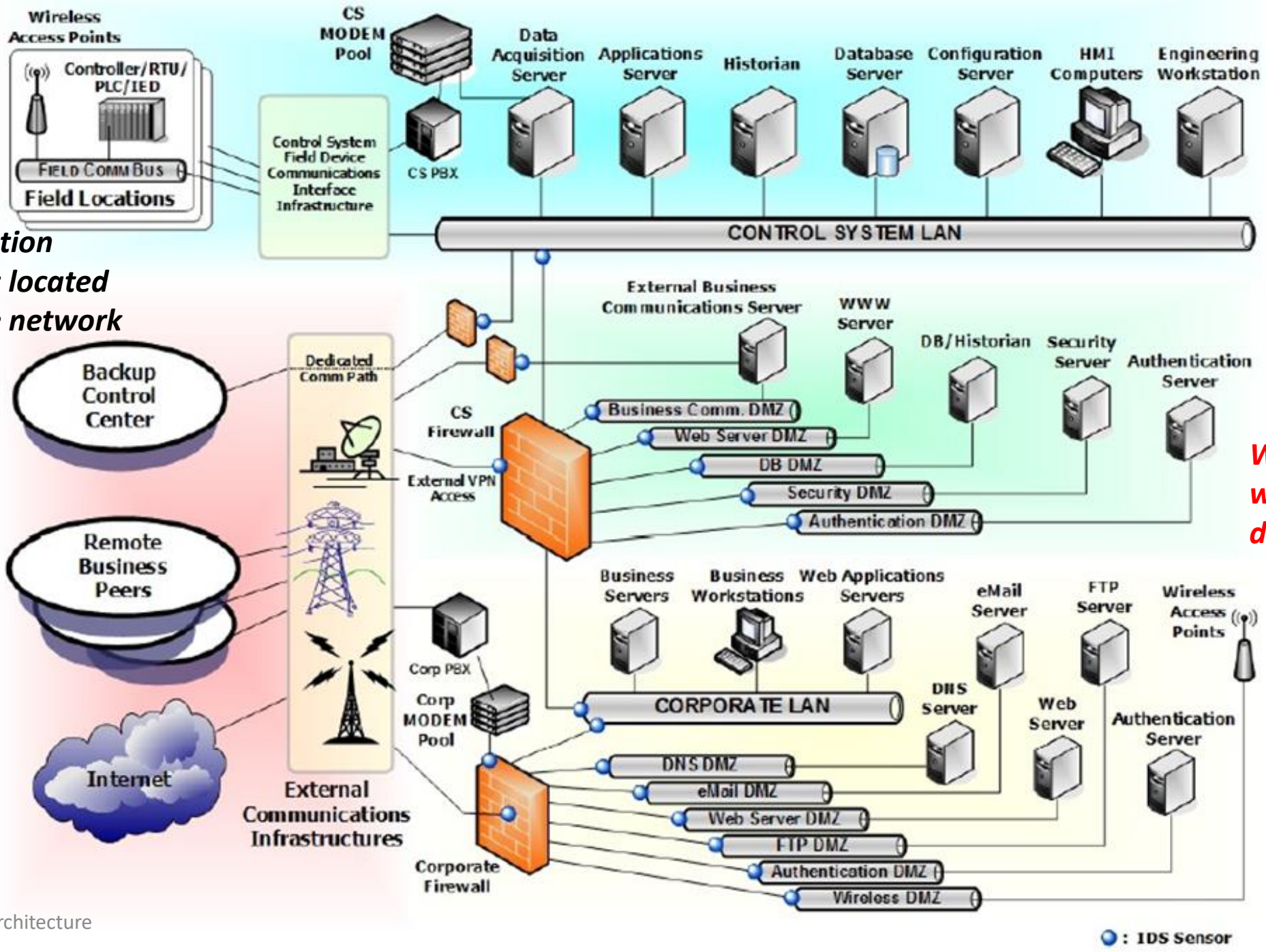

What is wrong with this logical diagram?

Agenda

- ✓ Introduction
 - ✓ Physical “air-gap” security and how we undermined it
- ✓ Firewalls
 - ✓ Types of firewalls
 - ✓ Some architectural patterns based on firewall placement
 - ✓ Firewalls have rules
- ✓ Intrusion Detection System (IDS) & Intrusion Prevention System (IPS)
- ✓ Defense in Depth with security zones (“Security Domains”)
- Project Team Assignment
- Preparation for Mid Term Exam

Team Assignment – Part 1 (do this part first)

1. Select a mission-based or service delivery information system your firm will develop and host in the cloud to support one or more governmental agencies

Use NIST Special Publication 800-60 Volume 1 Guide for Mapping Types of Information Systems to Security Categories

2. Determine the security categorization of the information and information system your firm will develop, host and support

Use NIST Special Publication 800-60 Volume 2 Appendices to Guide for Mapping Types of Information Systems to Security Categories

and

NIST FIPS 199 Standards for Security Categorization of Federal Information and Information Systems

- *Step 1 of the assignment:*

- *Complete FedRAMP System Security Plan's Cover Page, Sections 1, 2.1, 2.2, 9.1, and 9.3*
- *Complete FedRAMP System Security Plan's Attachment 10 – FIPS 199, including Table 2-1 "CSP Applicable Information Types with Security Impact Levels Using NIST SP 800-60 V2 R1"*

The level of detail should be one at which you would feel comfortable explaining to a group of senior executives

Team Assignment – Part 2a (do this part second)

3. Based on your team's Part 1 Deliverables (from 1 and 2) draft a logical network diagram of the information system architecture and infrastructure needed by your firm to develop and maintain the mission-based or service delivery information system for your government agency clients
 - You may use app.diagrams.net, Visio, or [Cyber Security Evaluation Tool](#) (available here: [CSET](#)) CSET's Diagram Tool, to draw the logical network diagram of the information system infrastructure
 - Use appropriate network symbols and annotation in your architectural diagram, include:
 - Information System Servers: e.g. Web Server(s), Application Server(s), Database Server(s), File Server(s)
 - *[NOTE: You may use a single server symbol for each server type in your diagram to represent a collection of servers of similar type]*
 - Use the cloud symbol to represent the Internet Be sure to use the cloud internet symbol to:
 - Separate your system's users from your cloud-based system
 - Separate any interconnected systems from your cloud-based system
 - Locations of end users (Note: They are not in the cloud)
 - Strongly consider having 3 parallel versions of the system: Development System, Test System, and Production System

Team Assignment – Part 2b (do this part third)

4. Transform the draft of the logical network diagram of the information system architecture you created in step 3 into a logical security architecture diagram that represents recommendations for technical security infrastructure for the information system
 - Use appropriate network symbols and annotation
 - Information System Servers: e.g. Web, Application, Database, File, ...
 - Groups of desktop/laptop computers illustrating organized within LANS of organizational units
 - Security zones (i.e. security domain areas) based on security categorizations
 - Appropriately placed switches, routers, firewalls, Intrusion Detection System(s) and/or Intrusion Protection Systems.
 - *Be sure to label all firewalls, IDSs IPS, and annotate to indicate the type of firewall technology and the type of IDS/IPS technology you placed in each location of your diagram*
 - Identify the system's boundaries, locations of interconnection(s) to the Internet, and ther information systems and to the Internet
 - Identify where and how various user groups including clients and remote staff access your organization various IT system via the Internet and illustrate the data flow between each user group and the information system
 - *Step 2 of the assignment:*
 - *Complete FedRAMP System Security Plan's Sections 8.1, 8.2, 9.2, 9.4, 10.1*
 - *Hand in your assignment individually via Canvas:*
 - *Each member of the team should submit an identical copy of the team's SSP document via your individual Canvas accounts by March 10.*
 - *Your SSP should have the following sections completed:*
 - *FedRAMP System Security Plan's Cover Page, Sections 1, 2.1, 2.2, 8.1, 8.2, 9.1, 9.2, 9.3, 9.4, and 10.1*
 - *If the network diagram does not fit into section 9.4 and display well, you may also include a copy as a separate PDF file with your hand-in via Canvas.*
 - *Complete FedRAMP System Security Plan's Attachment 10 – FIPS 199, including Table 2-1*
 - *Make sure that your team's identity (i.e. replace CSP Name with your Team # and members' names), and Information System Name, SSP Version and Version Date are listed on the cover page of the SSP document you hand in for your assignment cover page. Note: CSP = Cloud Service Provider.*

There is no single right answer: *The purpose of this exercise is to get you thinking about security architecture and to get you comfortable with documenting your ideas with diagrams*

Example of a student team's draft logical network diagram:



Preparation for Mid Term Exam

Emphasis on terminology and concepts

- Study lecture slides and notes
- Practice quizzes
- Readings
 - Textbook assigned chapters (look at practice questions in textbook)
 - Other readings (e.g. NIST and FIPS documents) as covered/discussed in class lectures

Subjects covered:

1. Threat environment
2. Planning and policy
3. Cryptography
4. Secure Networks (and Module A: Networking Concepts)
5. Firewalls, security architecture patterns, and IDS/IPS

Agenda

- ✓ Introduction
 - ✓ Physical “air-gap” security and how we undermined it
- ✓ Firewalls
 - ✓ Types of firewalls
 - ✓ Some architectural patterns based on firewall placement
 - ✓ Firewalls have rules
- ✓ Intrusion Detection System (IDS) & Intrusion Prevention System (IPS)
- ✓ Defense in Depth with security zones (“Security Domains”)
- ✓ Project Team Assignment
- ✓ Preparation for Mid Term Exam